

# Advancing with Simple & Powered Machines Curriculum Pack

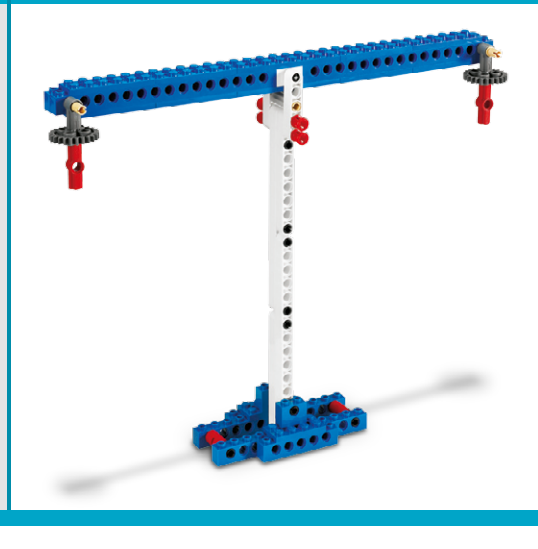

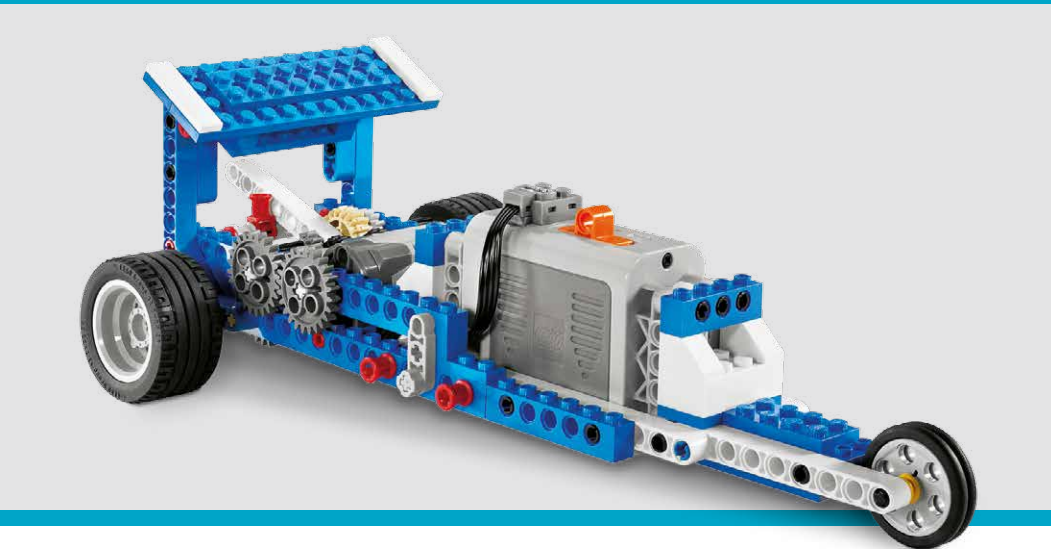
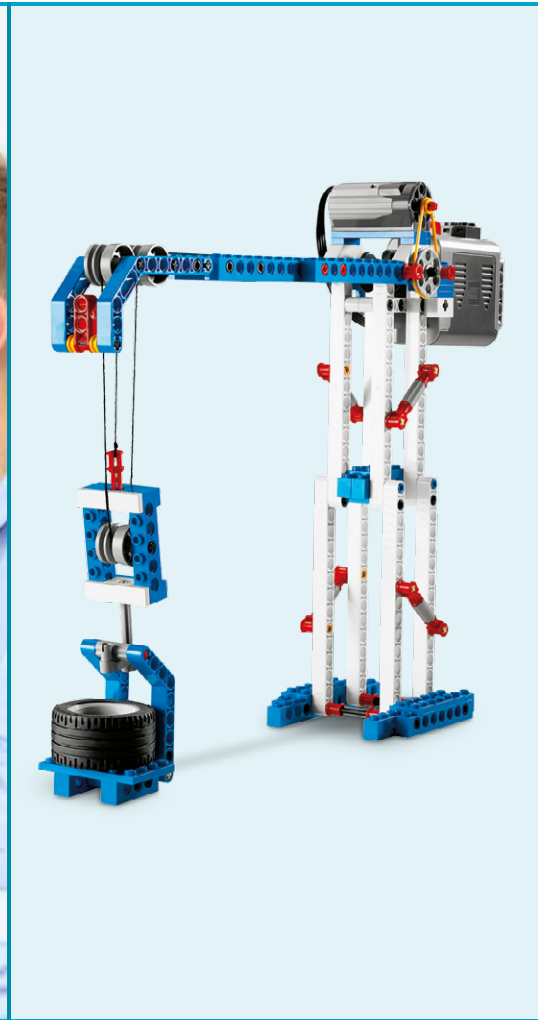

## Table of Contents

<b>1. Introduction</b> .....	<b>3</b>
Who is it for? .....	3
What is it for .....	3
What is in it? .....	4
Assessments .....	5
Three Levels of Progression .....	7
Classroom Management Tips .....	8
LEGO® Education 4C Approach .....	9
<b>2. Curriculum</b> .....	<b>10</b>
Observation Checklist .....	14
<b>3. Principle Models</b>	
Simple Machines .....	16
Mechanisms .....	72
Structures .....	96
<b>4. Activities</b>	
Beam Balance .....	102
Tower Crane .....	110
Ramp .....	118
Gear Racer .....	126
<b>5. Problem-Solving Activities</b>	
Catapult .....	134
Hand Cart .....	140
Winch .....	146
Merry-go-round .....	152
Watch Tower .....	158
Bridge .....	164
<b>6. Glossary</b> .....	<b>170</b>
<b>7. LEGO® Element Survey</b> .....	<b>175</b>

## Introduction

LEGO® Education is pleased to bring you the 'Advancing with Simple & Powered Machines', a curriculum pack filled with motivating and learning rich investigations and explorations into the world of machines and mechanisms.

### Who is it for?

The material is designed for middle school grades, although it can be relevant both prior to and after middle school. Working in pairs, students can build, investigate and learn from the models and activities.

Please refer to the Next Generation Science Standards (NGSS) and the Common Core State Standards grids in the 'Curriculum' section of this curriculum pack to see which activities match your current teaching program.

### What is it for?

The curriculum pack is for teachers who want to promote a challenging classroom environment and actively engage students in inquiry, reasoning and critical thinking. It is designed to apply the students' prior learning in science, technology, and mathematics together with engineering skills, creativity and intuition to actively create new knowledge.

The 'Advancing with Simple & Powered Machines' curriculum pack enables you to partially cover the following Crosscutting Concepts and overall Science and Engineering Practices, which have been set forth in the NGSS:

Science and Engineering Practices:

- Asking questions (for science) and defining problems (for engineering)
- Developing and using models
- Planning and carrying out investigations
- Analyzing and interpreting data
- Using mathematics and computational thinking
- Constructing explanations (for science) and designing solutions (for engineering)
- Engaging in argument from evidence
- Obtaining, evaluating, and communicating information

Crosscutting Concepts:

- Patterns
- Cause and Effect (Mechanism and explanation)
- Scale, Proportion, and Quantity
- Systems and System Models
- Energy and Matter (Flows, cycles, and conservation)
- Structure and Function
- Stability and Change



## What is in it?

### The 9686 Brick Set

The 'Advancing with Simple & Powered Machines' curriculum pack is designed to be used with the Simple & Powered Machines Set (9686). This set consists of 396 elements, including a motor, and full color Building Instructions booklets for fourteen activity models and thirty-seven principle models. The curriculum pack includes building instructions for four additional activity models. Some of the building instructions booklets can also be used with other LEGO® Education curriculum packs.

Included is a sorting tray and accompanying element overview showing all the different elements in the building set. Everything is stored in a sturdy blue storage box with a transparent lid.



### Building Instructions Booklets

For each of the activity models there are two building instructions, a booklet A and B. The building instructions are designed for two separate building processes, each building only half a model. By combining the two sub-assemblies, students work together to create a single, sophisticated and powerful model.



### Teacher's Notes

In the Teacher's Notes you will find all the information, tips and clues you need to set up a lesson. Each model the students build has specific key learning focus areas, vocabulary, questions, and answers, and further ideas for investigations.

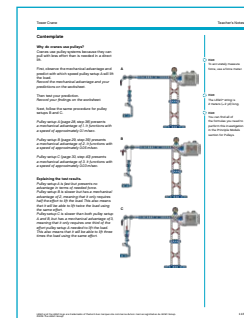
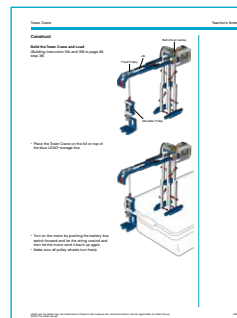

### Student Worksheets

Each worksheet guides students to predict, try out, measure and record data, change the models to compare and contrast findings, and draw conclusions.

Let the students work in pairs, predict and test their predictions at least three times to be confident that their results are reliable. Then they record their main data accordingly. At the end of each activity, the students are challenged to design and draw a device that applies the major concepts they have just explored.

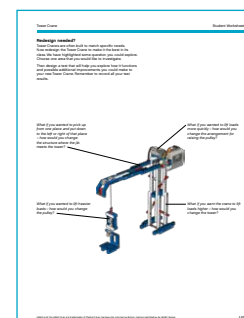
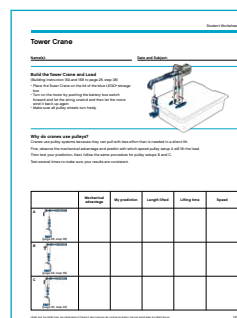

## Assessments

Three different assessment materials are provided for all four of the activities and the six problem-solving activities. These materials define clear learning goals before the students start each activity and motivate the students to challenge themselves throughout the learning process. You can also use these materials to assess your students' development in different learning areas.

### Student Worksheets

The student worksheets should be used to record each student's work throughout each activity. These worksheets are an easy-to-use assessment tool that will give you a clear picture of each student's level and achievement during each activity. They can also comprise a valuable part of the students' log books.

### Rubrics

#### 1. Activity Assessment

This rubric page can help students to evaluate their activity work according to learning goals based on two science-related NGSS Practices and one theme from the NGSS Crosscutting Concepts.

#### 2. Problem-Solving Assessment

This rubric can help students to evaluate their problem-solving work according to the engineering-related learning goals from the NGSS and learning objectives that are prominent in both the Common Core State Standards and 21st century skill set, specifically:

- How well did their design meet the requirements of the design brief?
- How creative was their solution?
- How well did their team work together?

Each rubric includes four levels: Bronze, Silver, Gold, and Platinum. The intention of the rubrics is to help students reflect on what they have done well in relation to the learning goals and what they might have done better. Students can write comments or questions in the 'Notes' section of each rubric.

Students should mark the rubric. If you prefer to emphasize formative assessment, ask the students to set their learning goals before they start each activity and to record the dates that correspond to their completion of each level.

You can also use the rubrics as a tool for your own evaluation of your students' work by marking a grade in the appropriate column and writing optional comments in the 'Notes' section.

### Observation Checklist

If a more science and engineering practices based approach to assessment is required in the problem-solving activities, you can use the Observation Checklist provided in the Teacher's Notes to assess students individually, in pairs, or in groups.

You can either use the Bronze (1), Silver (2), Gold (3), and Platinum (4) proficiency level descriptions, or use other assessment criteria that are relevant to your school context.

### Where can I find the assessment materials?

You can find the assessment materials in the Teacher's Notes for each of the activities and problem-solving activities.



The image shows a thumbnail of a document titled 'Observation Checklist Part 1'. It is a table with several columns and rows. The columns are labeled with proficiency levels: 'Bronze (1)', 'Silver (2)', 'Gold (3)', and 'Platinum (4)'. The rows are organized into sections with blue headers, including 'Science and Engineering Practices', 'Crosscutting Concepts', and 'Disciplinary Core Ideas'. Each cell in the table contains a small icon or a checkmark, indicating the presence or absence of a specific skill or concept.

## Three Levels of Progression

The 'Advancing with Simple & Powered Machines' curriculum pack consists of thirty-eight principle models, four activities, and six problem-solving activities. Each of these three components represents one level of progression, and each is described in more detail below.

### Principle Models

The principle models let students experience the mechanical and structural principles normally hidden away inside everyday machines and structures. The many easy-to-build models each present a hands-on demonstration of one of the concepts of simple machines, mechanisms and structures in a clear, straight-forward manner.

The principle models are a pathway for students to understand and integrate mechanical and structural principles applied in their own models.

### Activities

The four activities allow students to apply and develop their knowledge of science and engineering design. These activities create a positive learning environment and offer a complete scientific learning process in which students are able to make predictions, build models, run tests, record data, make comparisons, and improve their models in order to create a better solution.

These four activities connect with the concepts introduced by the principle models and help students to prepare for the increasingly difficult challenges they will meet in the problem-solving activities.

### Problem-Solving Activities

The six problem-solving activities all feature real-life problems that can be solved in several ways. Students will be able to test and integrate more than just one principle at a time.

The problem descriptions and the closely-defined design briefs are provided in the student worksheet. Descriptions of learning focus areas, materials needed, extra challenges and how to progress can be found in the Teacher's Notes.

The Teacher's Notes for each challenge provides tips on what and how to measure while at the same time carrying out fair testing of the solutions.

As a support we have included suggested solutions to the problems posed. Use these as 'tips and tricks', or print them and hang them as posters as inspiration for the students. The suggested problem-solving model solutions are only meant as guiding principles for any workable solution the students will come up with themselves.

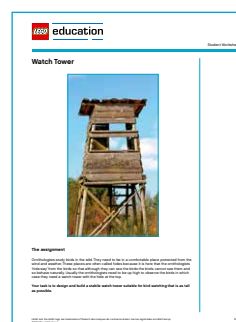
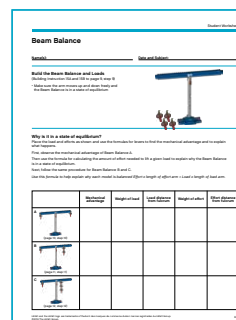
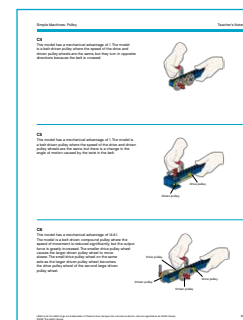
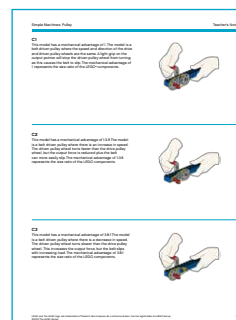

## Classroom Management Tips

### For Your First LEGO® Education Activity, and Beyond

#### 1. Before Class

- Open one of the LEGO® brick sets and sort the bricks according to the sorting suggestion on the back of the top card.
- Label the boxes so that you can recognize which box belongs to which student(s).
- Download the curriculum pack from the URL that is printed on the lid of each set.
- Try to complete the activity using the student worksheets.

#### 2. During Class

- Let the students sort their LEGO brick sets at the beginning of the first lesson.
- Have the students use the lid of their set as a working tray.
- Use a jar to collect stray pieces.
- Make adjustments in order to challenge the students who are ready to improve and develop new skills.

#### 3. After Class

- Plan to stop the lesson with enough time to allow the students to tidy up.
- If you did not finish the activity, store the LEGO sets and the models so that they are ready for the next lesson.
- Evaluate the lesson.
- Book a LEGO Education training session if you need further inspiration.

#### How much time do I need?

A 90-minute class period is ideal to be able to explore, build, and test in depth all the extension ideas built into the material and for the students to make any creative variations of their own.

#### How do I handle the building instructions booklets?

For easy classroom management we suggest storing the building instructions booklets in separate plastic folders in binders so that they are at hand and ready to use at the beginning of each lesson.

You can also ask your students to download the building instructions booklets from the URL that is printed on the lid of each set, and save them to their devices.

#### What's needed in my classroom?

Tables may be pushed aside to let models roll across a smooth floor. Ideally, a computer or computers should be available for students to explore the Jack and Jill animated activity briefings.

Students need to be able to construct in pairs facing each other or side-by-side. From teachers and classrooms we have learned that cafeteria-type trays are ideal to build on, and to stop elements rolling onto the floor. It is also an advantage to have a cupboard or shelves to store the sets lying flat with any unfinished models on top of them.

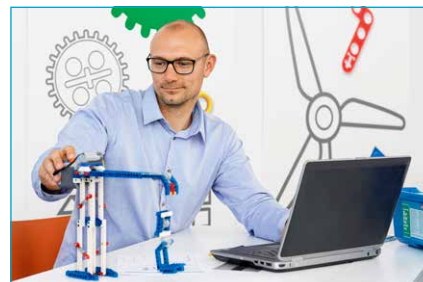



## LEGO® Education 4C Approach

The activities follow LEGO® Education's 4C approach; Connect, Construct, Contemplate, and Continue. This enables you to progress naturally through the activities.

### Connect

Creating a connection between a past and new learning experience stimulates the growth of new knowledge. Each activity therefore provides a short text with insights into the purpose and function of the specific model. The text is supported by a short video of a real-life machine similar to the LEGO model. Use the text and video as a starting point for a class discussion or you could draw on your own experiences to provide an engaging introduction to the activity.

### Construct

The construction of models engages both hands and minds. Using the building instructions, students build models embodying the concepts related to the key learning areas. Tips are provided for testing and ensuring each model functions as intended.

### Contemplate

Contemplating is the opportunity to deepen the understanding of previous knowledge and new experiences. Based on scientific method, the activities encourage the students to discuss and reflect on their investigations, and adapt their ideas to the task at hand.

Each activity requires the students to predict an outcome, test, calculate and record their findings. We suggest encouraging the students to present their findings together with their explanations and rationales to each other.

We suggest stimulating the students' reflections on their investigations by having them consider patterns or trends in their findings, identify variables and describing advantages and disadvantages in model function and design.



This stage in the student's work process provides an opportunity for you to begin evaluating the learning outcome and progress of the individual student.

### Continue

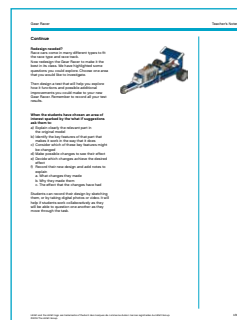
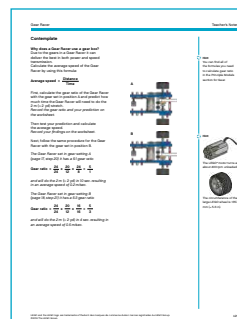
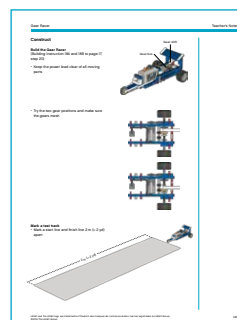
Learning is always more enjoyable and creative when it is adequately challenging. Maintaining this challenge and the pleasure of accomplishment naturally inspires the continuation of more advanced work. The open-ended continue activities challenge the students through a series of 'what if' questions to focus on particular features of the model that might be re-designed to give improved and optimized performance.





# Curriculum Grid

Objective Number	<b>NGSS Grade 6-8</b>   = Fully covered  = Partially covered	Activities				Problem-Solving Activities					
		Beam Balance	Tower Crane	Ramp	Gear Racer	Catapult	Handcart	Winch	Merry-Go-Round	Watch Tower	Bridge
<b>Disciplinary Core Ideas: Physical Science</b>											
1	MS-PS2 Motion and Stability: Forces and Interactions										
2	MS-PS3 Energy										
<b>Crosscutting Concepts</b>											
1	Patterns										
2	Cause and effect: Mechanism and explanation										
3	Scale, proportion, and quantity										
4	Systems and system models										
5	Energy and matter: Flows, cycles, and conservation										
6	Structure and Function										
7	Stability and change										
<b>Science and Engineering Practices</b>											
1	Asking questions and Defining Problems										
2	Developing and using models										
3	Planning and carrying out investigations										
4	Analyzing and interpreting data										
5	Using mathematics, Informational and Computer Technology, and computational thinking										
6	Constructing explanations and designing solutions										
7	Engaging in argument from evidence										
8	Obtaining, evaluating, and communicating information										

# Curriculum Highlights

Objective Number	Common Core Mathematics Standards Grade 6-8  ● = Fully covered ◐ = Partially covered	Activities				Problem-Solving Activities					
		Beam Balance	Tower Crane	Ramp	Gear Racer	Catapult	Handcart	Winch	Merry-Go-Round	Watch Tower	Bridge
<b>Mathematical Practice</b>											
MP1	Make sense of problems and persevere in solving them	◐	◐	◐	◐	◐	◐	◐	◐	◐	◐
MP2	Reason abstractly and quantitatively	◐	◐	◐	◐	◐	◐	◐	◐	◐	◐
MP3	Construct viable arguments and critique the reasoning of others	◐	◐	◐	◐	◐	◐	◐	◐	◐	◐
MP4	Model with mathematics	●	●	●	●	●	●	●	●	●	●
MP5	Use appropriate tools strategically	◐	◐	◐	◐	◐	◐	◐	◐	◐	◐
MP6	Attend to precision	◐	◐	◐	◐	◐	◐	◐	◐	◐	◐
MP7	Look for and make use of structure	◐	◐	◐	◐	◐	◐	◐	◐	◐	◐
MP8	Look for and express regularity in repeated reasoning	◐	◐	◐	◐	◐	◐	◐	◐	◐	◐
<b>Ratios &amp; Proportional Relationships</b>											
6.RP.A	Understand ratio concepts and use ratio reasoning to solve problems	◐		◐	◐		◐		◐		◐
7.RP.A	Analyze proportional relationships and use them to solve real-world and mathematical problems	◐		◐	◐	◐					
<b>The Number System</b>											
6.NS.B	Compute fluently with multi-digit numbers and find common factors and multiples	◐	◐	◐	◐	◐	◐	◐	◐	◐	◐
7.NS.A	Apply and extend previous understandings of operations with fractions	◐	◐	◐	◐	◐	◐	◐	◐	◐	◐
<b>Expressions &amp; Equations</b>											
6.EE.A	Apply and extend previous understandings of arithmetic to algebraic expressions	◐	◐	◐	◐	◐	◐	◐	◐	◐	◐
6.EE.B	Reason about and solve one-variable equations and inequalities	◐	◐	◐	◐	◐	◐	◐	◐	◐	◐
6.EE.C	Represent and analyze quantitative relationships between dependent and independent variables	◐	◐	◐	◐	◐	◐	◐	◐	◐	◐
7.EE.B	Solve real-life and mathematical problems using numerical and algebraic expressions and equations	●	●	●	●	●	●	●	●	●	●
8.EE.A	Work with radicals and integer exponents	◐	◐	◐	◐	◐	◐	◐	◐	◐	◐
8.EE.B	Understand the connections between proportional relationships, lines, and linear equations			◐	◐						
8.EE.C	Analyze and solve linear equations and pairs of simultaneous linear equations	◐	◐	◐	◐						
<b>Function</b>											
8.F.A	Define, evaluate, and compare functions	◐	◐	◐	◐						
8.F.B	Use functions to model relationships between quantities			◐	◐	◐		◐	◐		
<b>Geometry</b>											
6.G.A	Solve real-world and mathematical problems involving area, surface area, and volume	◐								◐	◐
7.G.A	Draw construct, and describe geometrical figures and describe the relationships between them										◐
7.G.B	Solve real-life and mathematical problems involving angle measure, area, surface area, and volume						◐	◐	◐	◐	◐
8.G.A	Understand congruence and similarity using physical models, transparencies, or geometry software	◐									◐
<b>Statistics &amp; Probability</b>											
6.SPA	Develop understanding of statistical variability	◐	◐	◐	◐	◐	◐				
8.SPA	Investigate patterns of association in bivariate data				◐						

Objective Number	<b>Common Core English Language Arts Grade 6-8</b>   = Fully covered  = Partially covered	Activities				Problem-Solving Activities					
		Beam Balance	Tower Crane	Ramp	Gear Racer	Catapult	Handcart	Winch	Merry-Go-Round	Watch Tower	Bridge
<b>Speaking and Listening</b>											
SL 6.1	Engage effectively in a range of collaborative discussions (one-on-one, in groups, and teacher-led) with diverse partners on grade 6 topics, texts, and issues, building on others' ideas and expressing their own clearly	●	●	●	●	●	●	●	●	●	●
SL 6.2	Interpret information presented in diverse media and formats (e.g., visually, quantitatively, orally) and explain how it contributes to a topic, text, or issue under study	◐	◐	◐	◐	◐	◐	◐	◐	◐	◐
SL 6.3	Delineate a speaker's argument and specific claims, distinguishing claims that are supported by reasons and evidence from claims that are not	◐	◐	◐	◐	◐	◐	◐	◐	◐	◐
SL 6.4	Present claims and findings, sequencing ideas logically and using pertinent descriptions, facts, and details to accentuate main ideas or themes; use appropriate eye contact, adequate volume, and clear pronunciation	●	●	●	●	●	●	●	●	●	●
SL 6.5	Include multimedia components (e.g., graphics, images, music, sound) and visual displays in presentations to clarify information	◐	◐	◐	◐	◐	◐	◐	◐	◐	◐
SL 6.6	Adapt speech to a variety of contexts and tasks, demonstrating command of formal English when indicated or appropriate. (See grade 6 Language standards 1 and 3 for specific expectations.)	●	●	●	●	●	●	●	●	●	●
SL 7.1	Engage effectively in a range of collaborative discussions (one-on-one, in groups, and teacher-led) with diverse partners on grade 7 topics, texts, and issues, building on others' ideas and expressing their own clearly	●	●	●	●	●	●	●	●	●	●
SL 7.2	Analyze the main ideas and supporting details presented in diverse media and formats (e.g., visually, quantitatively, orally) and explain how the ideas clarify a topic, text, or issue under study	◐	◐	◐	◐	◐	◐	◐	◐	◐	◐
SL 7.4	Present claims and findings, emphasizing salient points in a focused, coherent manner with pertinent descriptions, facts, details, and examples; use appropriate eye contact, adequate volume, and clear pronunciation	●	●	●	●	●	●	●	●	●	●
SL 7.5	Include multimedia components and visual displays in presentations to clarify claims and findings and emphasize salient points	◐	◐	◐	◐	◐	◐	◐	◐	◐	◐
SL 7.6	Adapt speech to a variety of contexts and tasks, demonstrating command of formal English when indicated or appropriate. (See grade 7 Language standards 1 and 3 here for specific expectations.)	◐	◐	◐	◐	◐	◐	◐	◐	◐	◐
SL 8.1	Engage effectively in a range of collaborative discussions (one-on-one, in groups, and teacher-led) with diverse partners on grade 8 topics, texts, and issues, building on others' ideas and expressing their own clearly	●	●	●	●	●	●	●	●	●	●
SL 8.2	Analyze the purpose of information presented in diverse media and formats (e.g., visually, quantitatively, orally) and evaluate the motives (e.g., social, commercial, political) behind its presentation	◐	◐	◐	◐	◐	◐	◐	◐	◐	◐
SL 8.4	Present claims and findings, emphasizing salient points in a focused, coherent manner with relevant evidence, sound valid reasoning, and well-chosen details; use appropriate eye contact, adequate volume, and clear pronunciation	●	●	●	●	●	●	●	●	●	●
SL 8.5	Integrate multimedia and visual displays into presentations to clarify information, strengthen claims and evidence, and add interest	◐	◐	◐	◐	◐	◐	◐	◐	◐	◐
SL 8.6	Adapt speech to a variety of contexts and tasks, demonstrating command of formal English when indicated or appropriate. (See grade 8 Language standards 1 and 3 here for specific expectations.)	●	●	●	●	●	●	●	●	●	●

Objective Number	<b>Common Core English Language Arts Grade 6-8</b>   = Fully covered  = Partially covered	Activities				Problem-Solving Activities					
		Beam Balance	Tower Crane	Ramp	Gear Racer	Catapult	Handcart	Winch	Merry-Go-Round	Watch Tower	Bridge
<b>Reading Standards for Literacy in Science and Technical</b>											
RST 6-8.1	Cite specific textual evidence to support analysis of science and technical texts.	●	●	●	●	●	●	●	●	●	●
RST 6-8.2	Determine the central ideas or conclusions of a text; provide an accurate summary of the text distinct from prior knowledge or opinions.	●	●	●	●	●	●	●	●	●	●
RST 6-8.3	Follow precisely a multistep procedure when carrying out experiments, taking measurements, or performing technical tasks.	●	●	●	●	●	●	●	●	●	●
RST 6-8.4	Determine the meaning of symbols, key terms, and other domain-specific words and phrases as they are used in a specific scientific or technical context relevant to grades 6-8 texts and topics.	●	●	●	●	●	●	●	●	●	●
RST 6-8.5	Analyze the structure an author uses to organize a text, including how the major sections contribute to the whole and to an understanding of the topic.	●	●	●	●	●	●	●	●	●	●
RST 6-8.6	Analyze the author's purpose in providing an explanation, describing a procedure, or discussing an experiment in a text.	◐	◐	◐	◐	◐	◐	◐	◐	◐	◐
RST 6-8.7	Integrate quantitative or technical information expressed in words in a text with a version of that information expressed visually (e.g., in a flowchart, diagram, model, graph, or table).	◐	◐	◐	◐	◐	◐	◐	◐	◐	◐
RST 6-8.10	By the end of grade 8, read and comprehend science/technical texts in the grades 6-8 text complexity band independently and proficiently.	●	●	●	●	●	●	●	●	●	●
<b>Writing Standards for Literacy in History/Social Studies, Science, &amp; Technical Subjects</b>											
WHST 6-8.2	Write informative/explanatory texts, including the narration of historical events, scientific procedures/ experiments, or technical processes.	●	●	●	●	●	●	●	●	●	●
WHST 6-8.4	Produce clear and coherent writing in which the development, organization, and style are appropriate to task, purpose, and audience.	●	●	●	●	●	●	●	●	●	●
WHST 6-8.5	With some guidance and support from peers and adults, develop and strengthen writing as needed by planning, revising, editing, rewriting, or trying a new approach, focusing on how well purpose and audience have been addressed.	◐	◐	◐	◐	◐	◐	◐	◐	◐	◐
WHST 6-8.7	Conduct short research projects to answer a question (including a self-generated question), drawing on several sources and generating additional related, focused questions that allow for multiple avenues of exploration.	◐	◐	◐	◐	◐	◐	◐	◐	◐	◐
WHST 6-8.10	Write routinely over extended time frames (time for reflection and revision) and shorter time frames (a single sitting or a day or two) for a range of discipline-specific tasks, purposes, and audiences.	◐	◐	◐	◐	◐	◐	◐	◐	◐	◐

<b>Observation Checklist Part 1</b>  <b>Science and Engineering Practices</b> <b>Grade 6-8</b>  Use the Bronze (1), Silver (2), Gold (3), and Platinum (4) proficiency level descriptions, or another assessment scale that is relevant to your school context.		Name(s)									
<b>Practice 1: I observed students asking questions</b>											
a	to seek more information.										
b	to seek evidence for a claim.										
c	to challenge a claim or interpretation of data.										
d	to identify and understand independent and dependent variables.										
e	that can be investigated in this class.										
<b>Practice 2: I observed students developing and/or using a model</b>											
a	to explore its limitations.										
b	to explore what happens when parts of the model are changed.										
c	to show the relationship between variables.										
d	to make predictions.										
e	to generate data about what they are designing or investigating.										
<b>Practice 3: I observed students planning and carrying out investigations</b>											
a	that included independent and dependent variables and controls.										
b	that included appropriate measurement and recording tools.										
c	that tested the accuracy of various methods for collecting data.										
d	to collect data to answer a scientific question or test a design solution.										
e	to test the performance of a design under a range of conditions.										
<b>Practice 4: I observed students analyzing and interpreting data</b>											
a	by constructing graphs.										
b	to identify linear and non-linear relationships.										
c	to distinguish between cause and effect vs. correlational relationships.										
d	by using statistics and probability such as mean and percentage.										
e	to determine similarities and differences in findings.										
f	to determine a way to optimize their solution to a design problem.										
Notes:											

Observation Checklist Part 2		Name(s)									
<b>Science and Engineering Practices</b> <b>Grade 6-8</b>  Use the Bronze (1), Silver (2), Gold (3), and Platinum (4) proficiency level descriptions, or another assessment scale that is relevant to your school context.											
<b>Practice 5: I observed students using mathematics and computational thinking</b>											
a	by including mathematical representations in their explanations and design solutions.										
b	by using an algorithm to solve a problem.										
c	by using concepts such as ratio, rate, percent, basic operations, or simple algebra.										
<b>Practice 6: I observed students constructing explanations and design solutions</b>											
a	that included quantitative and qualitative relationships.										
b	that are based on scientific ideas, laws and theories.										
c	that connect scientific ideas, laws, and theories to their own observations.										
d	that apply scientific ideas, laws, and theories.										
e	to help optimize design ideas while making tradeoffs and revisions.										
<b>Practice 7: I observed students engaging in arguments from evidence</b>											
a	that compare and critique two arguments on the same topic.										
b	while respectfully providing and receiving critiques using appropriate evidence.										
c	while presenting oral or written statements supported by evidence.										
d	while evaluating different design solutions based on agreed-upon criteria and constraints.										
<b>Practice 8: I observed students evaluating and communicating information</b>											
a	when they read scientific text adapted for the classroom.										
b	when they read or wrote information in combinations of text, graphs, diagrams, and other media.										
c	when they created presentations about their investigations and/or design solutions.										
Notes:											

# Lever

Student Worksheet

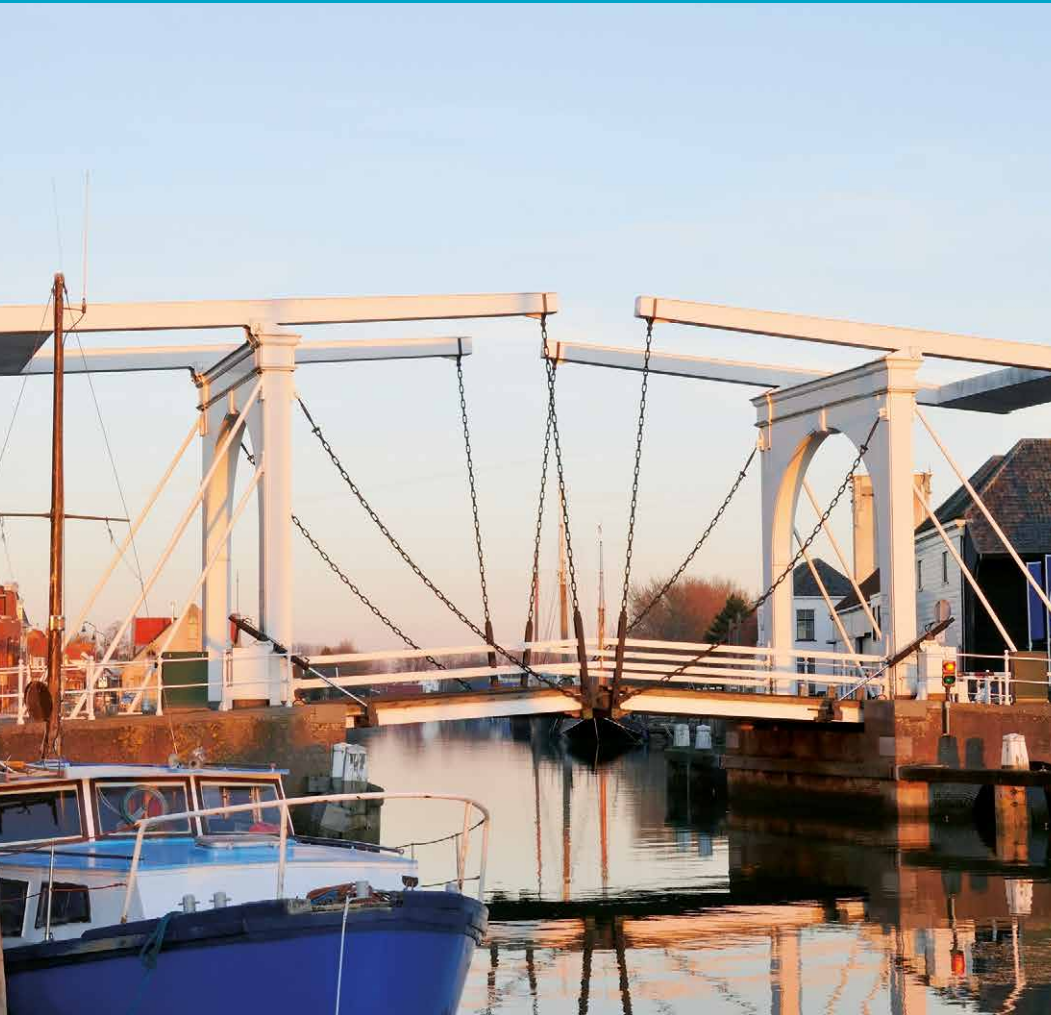



## Simple Machines: Lever

The lever is probably the most commonly used simple machine. A lever is a rigid bar or solid object that is used to transfer force.

With a fulcrum, the lever can be used to change the force that is applied (effort), alter the direction, and change the distance of movement. Effort, a fulcrum and a load are three features that are common in every lever.

Depending on the positions of these shared features, you can distinguish between first, second or third class levers.

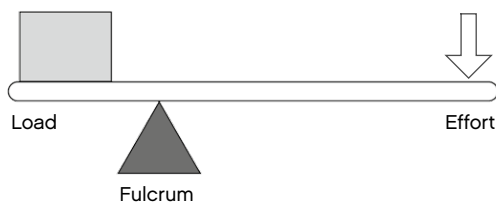

**First class levers** have the fulcrum positioned between the effort and the load. Common examples of first class levers include a seesaw, a crowbar, pliers, and scissors.

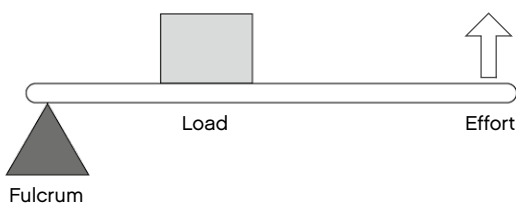

**Second class levers** have the fulcrum and the effort at opposite ends and the load positioned between the two. Common examples of second class levers include nut crackers, wheel barrows, and bottle openers.

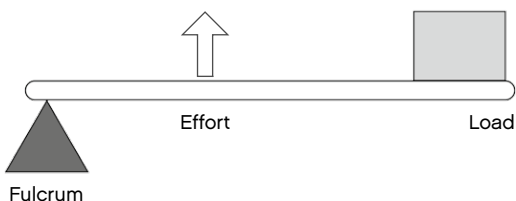

**Third class levers** have the fulcrum and the load at opposite ends and the effort positioned between the two. Common examples of third class levers include tweezers and ice tongs.

### Did you know?

The term lever derives from the French word *levier* which means 'to raise'.

## The Mechanical Advantage of a Lever

The mechanical advantage of a lever is the ratio of the length of the effort arm to the length of the load arm.

It can be calculated using the following formula:

$$\text{Mechanical advantage} = \frac{\text{Length of effort arm}}{\text{Length of load arm}}$$

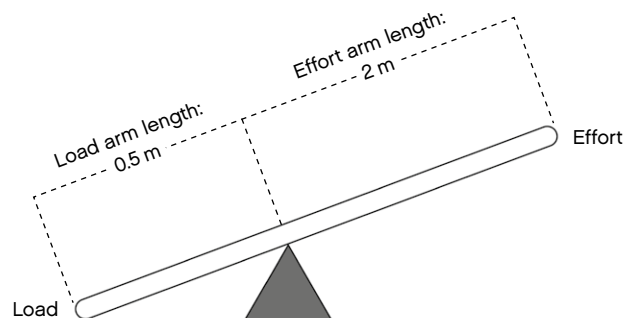

The mechanical advantage of this 1st class lever is:

$$\text{Mechanical advantage} = \frac{2 \text{ m}}{0.5 \text{ m}}$$

$$\text{Mechanical advantage} = 4$$

The amount of effort needed to lift a given load with any class of lever can be calculated using this formula:

$$\text{Effort force} \times \text{length of effort arm} = \text{Load force} \times \text{length of load arm}$$

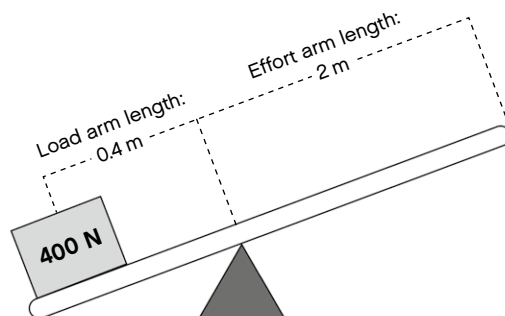

$$\text{Effort} \times 2 \text{ m} = 400 \text{ N} \times 0.4 \text{ m}$$

$$\text{Effort} = \frac{400 \text{ N} \times 0.4 \text{ m}}{2 \text{ m}}$$

$$\text{Effort} = 80 \text{ N}$$

Using this 1st class lever to lift a 400 N load would only need an effort of 80 N. However, the effort end of the lever must move five times the distance of the load.

**A1**

**Build A1 book I, pages 2 to 3**

Calculate the mechanical advantage of this lever.  
Then define the class of lever.

---



---



---



---

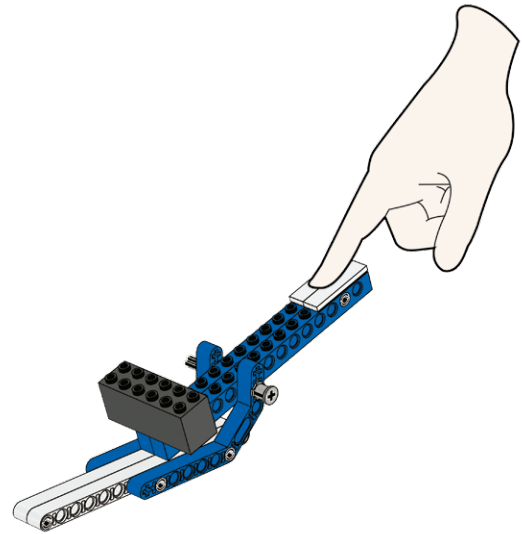

**A2**

**Build A2 book I, pages 4 to 5**

Calculate the mechanical advantage of this lever.  
Then define the class of lever.

---



---



---



---

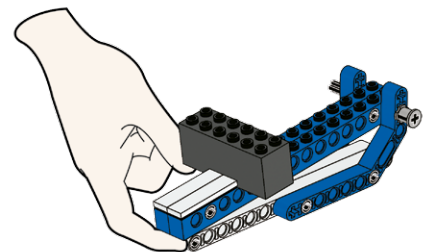

**A3**

**Build A3 book I, pages 6 to 7**

Calculate the mechanical advantage of this lever.  
Then define the class of lever.

---



---



---



---

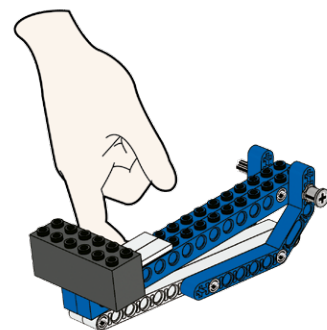

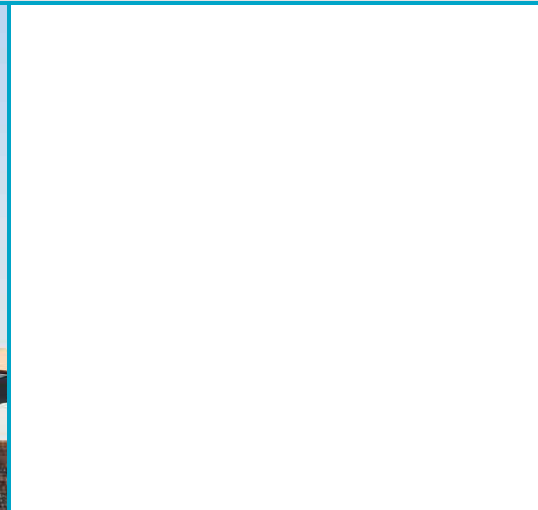
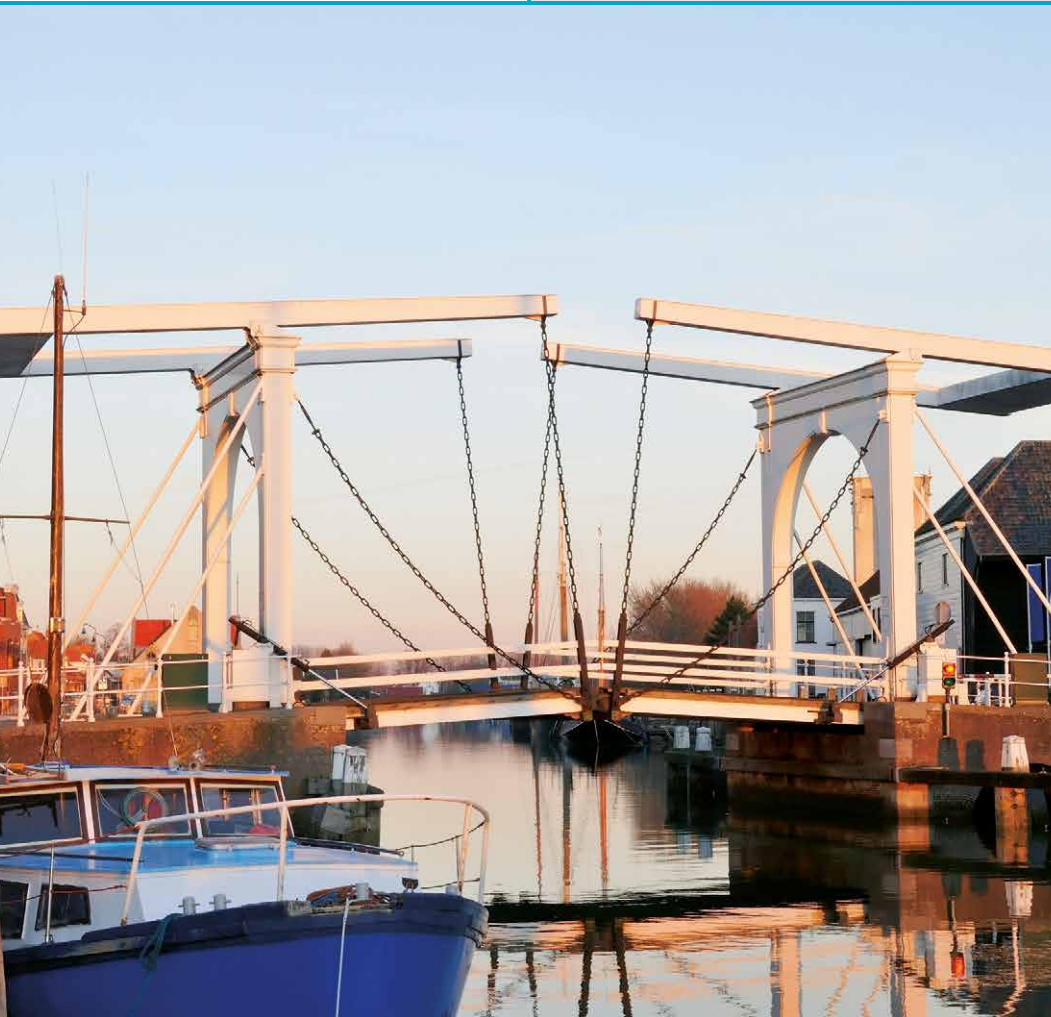

## Simple Machines: Lever

The lever is probably the most commonly used simple machine. A lever is a rigid bar or solid object that is used to transfer force.

With a fulcrum, the lever can be used to change the force that is applied (effort), alter the direction, and change the distance of movement. Effort, a fulcrum and a load are three features that are common in every lever.

Depending on the positions of these shared features, you can distinguish between first, second or third class levers.

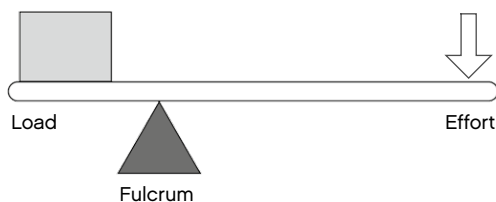

**First class levers** have the fulcrum positioned between the effort and the load. Common examples of first class levers include a seesaw, a crowbar, pliers, and scissors.

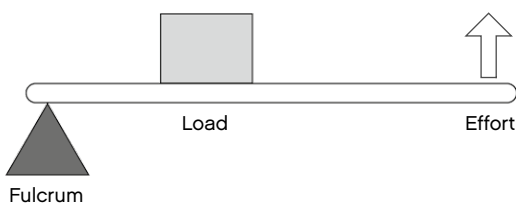

**Second class levers** have the fulcrum and the effort at opposite ends and the load positioned between the two. Common examples of second class levers include nut crackers, wheel barrows, and bottle openers.

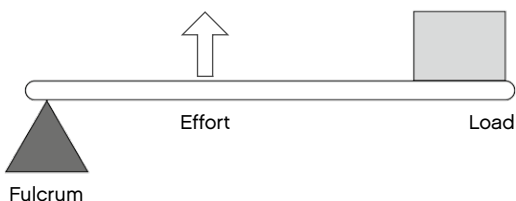

**Third class levers** have the fulcrum and the load at opposite ends and the effort positioned between the two. Common examples of third class levers include tweezers and ice tongs.

### Did you know?

The term lever derives from the French word *levier* which means 'to raise'.

## The Mechanical Advantage of a Lever

The mechanical advantage of a lever is the ratio of the length of the effort arm to the length of the load arm.

It can be calculated using the following formula:

$$\text{Mechanical advantage} = \frac{\text{Length of effort arm}}{\text{Length of load arm}}$$

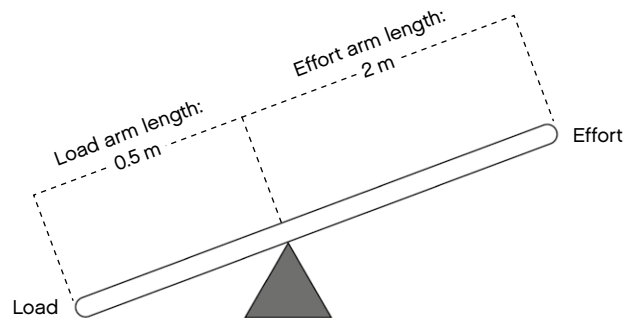

The mechanical advantage of this 1st class lever is:

$$\text{Mechanical advantage} = \frac{2 \text{ m}}{0.5 \text{ m}}$$

$$\text{Mechanical advantage} = 4$$

The amount of effort needed to lift a given load with any class of lever can be calculated using this formula:

$$\text{Effort force} \times \text{length of effort arm} = \text{Load force} \times \text{length of load arm}$$

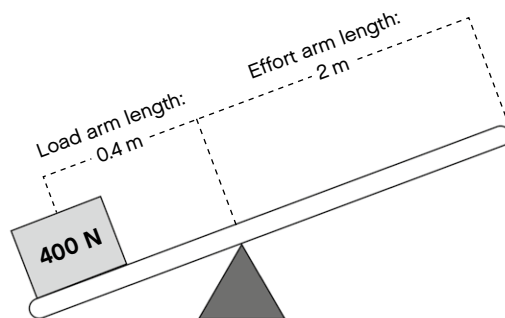

$$\text{Effort} \times 2 \text{ m} = 400 \text{ N} \times 0.4 \text{ m}$$

$$\text{Effort} = \frac{400 \text{ N} \times 0.4 \text{ m}}{2 \text{ m}}$$

$$\text{Effort} = 80 \text{ N}$$

Using this 1st class lever to lift a 400 N load would only need an effort of 80 N. However, the effort end of the lever must move five times the distance of the load.

**A1**

This model has a mechanical advantage of 3. It is a first class lever. It has the effort and load at opposite ends with the fulcrum in between.

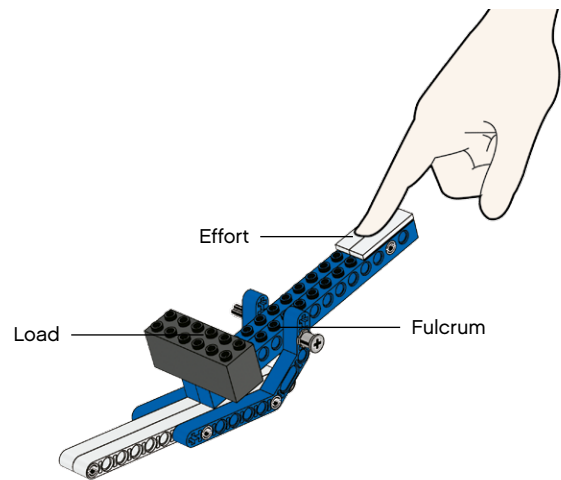
**A2**

This model has a mechanical advantage of 1.3. It is a second class lever. It has the effort and fulcrum at opposite ends and the load in between.

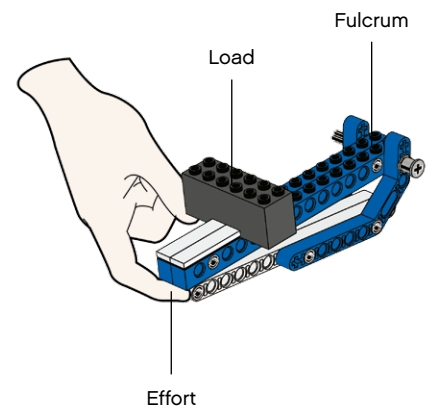
**A3**

This model has a mechanical advantage of 0.8, meaning that a greater effort force is needed to lift the load than the load force. However, the load moves further than the effort. This is a third class lever. It has the fulcrum and load at opposite ends and the effort in between.

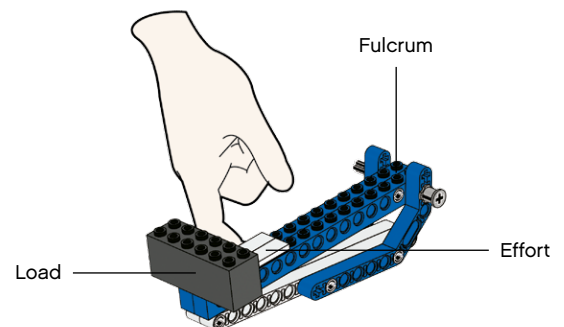

# Wheel and Axle

Student Worksheet

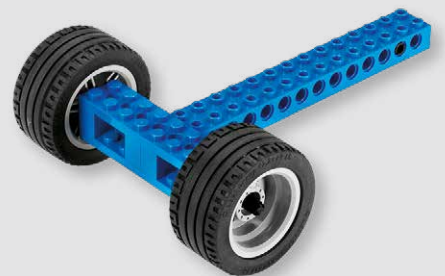
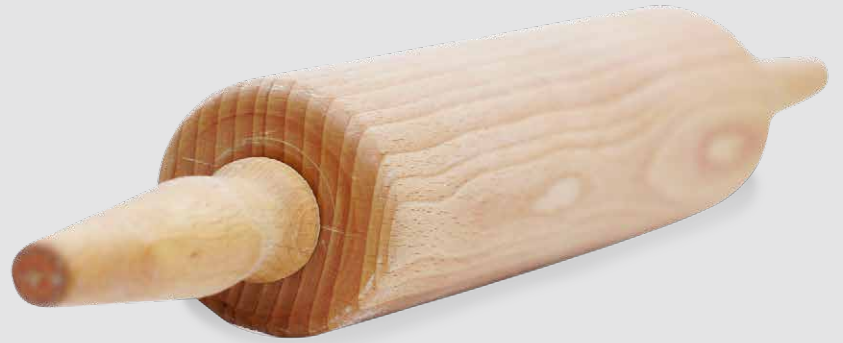



## Simple Machines: Wheel and Axle

Wheels and axles are usually circular objects, often a big wheel and a smaller axle, rigidly secured to one another.

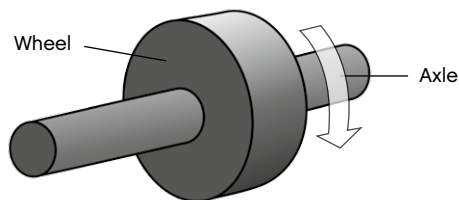

The wheel and axle will always rotate at the same speed. Due to the bigger circumference of the wheel, the surface of the wheel will turn at a greater speed – and with a greater distance too.

Placing a load on a wheeled vehicle almost always reduces friction compared to dragging it over the ground. Wheels in science and engineering are not always used for transport. Wheels with grooves are called pulleys and wheels with teeth are called gears.

Common examples of wheels and axles are rolling pins, roller skates and pushcarts.

### Did you know?

The first constructed wheel found so far was made by the Sumerians some 5,600 years ago.

## The Mechanical Advantage of a Wheel and Axle

The mechanical advantage of wheels and axles describes the ratio of rotation between the wheel and axle. Depending on where the effort is applied, the mechanical advantage can be calculated using the following formula:

$$\text{Mechanical advantage} = \frac{D_w}{D_a}$$

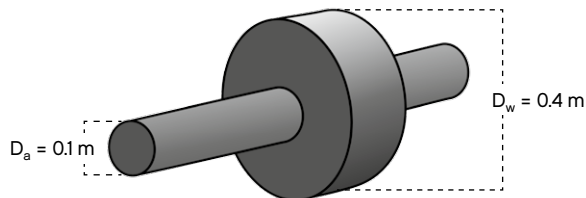

The mechanical advantage of this wheel and axle is 4:1 or 4 if the effort is applied to the axle. Meaning four times an increase in speed and distance, but at the same time a decrease in force by four times.

If the effort is applied to the wheel the mechanical advantage is 1:4, meaning a four times decrease in speed and distance, but four times increase in force.

 **Hint:**



The diameter of large LEGO® wheels are 43.2 mm ( $\approx 1.7 \text{ in}$ ).



The diameter of LEGO axles are 4.7 mm ( $\approx 0.18 \text{ in}$ ).

**B1****Build B1 book I, pages 8 to 9**

Push the model along the table in a straight line.  
Then try driving it in a zigzag pattern with sharp turns.  
Explain what happens and why.

---



---



---

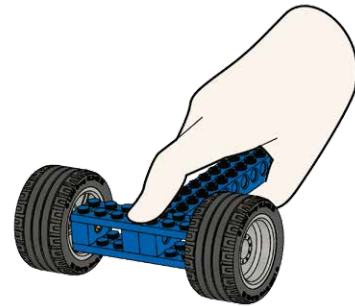

---

**B2****Build B2 book I, pages 10 to 11**

Push the model along the table in a straight line.  
Then try driving it in a zigzag pattern with sharp turns.  
Explain what happens and why, compare with the model above.

---



---



---

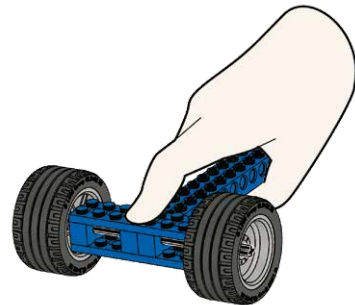

---

**B3****Build B3 book I, pages 12 to 15**

Push the model along the table in a straight line.  
Then try driving it in a zigzag pattern with sharp turns.  
Explain what happens and why, compare with the models above.

---



---



---



---

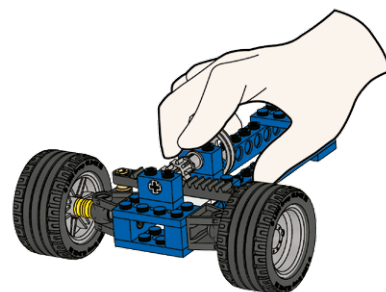

**B4**

**Build B4 book I, pages 16 to 17**

Turn the handle and explain what happens.

---



---



---



---

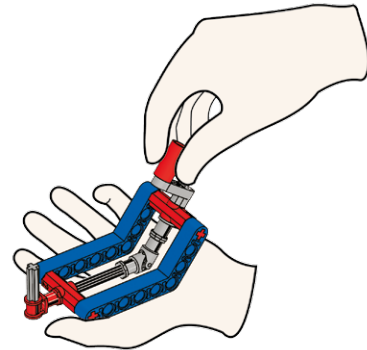

**B5**

**Build the model as shown.**

Calculate the mechanical advantage of a LEGO® wheel and axle.

---



---



---



---



# Wheel and Axle

Teacher's Notes

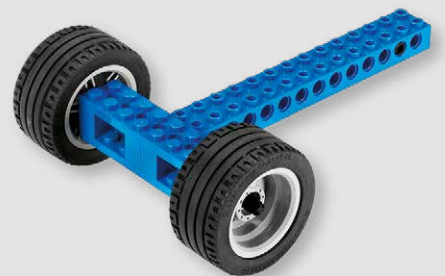

## Simple Machines: Wheel and Axle

Wheels and axles are usually circular objects, often a big wheel and a smaller axle, rigidly secured to one another.

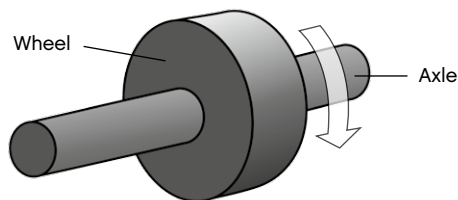

The wheel and axle will always rotate at the same speed. Due to the bigger circumference of the wheel, the surface of the wheel will turn at a greater speed – and with a greater distance too.

Placing a load on a wheeled vehicle almost always reduces friction compared to dragging it over the ground. Wheels in science and engineering are not always used for transport. Wheels with grooves are called pulleys and wheels with teeth are called gears.

Common examples of wheels and axles are rolling pins, roller skates and pushcarts.

### Did you know?

The first constructed wheel found so far was made by the Sumerians some 5,600 years ago.

## The Mechanical Advantage of a Wheel and Axle

The mechanical advantage of wheels and axles describes the ratio of rotation between the wheel and axle. Depending on where the effort is applied, the mechanical advantage can be calculated using the following formula:

$$\text{Mechanical advantage} = \frac{D_w}{D_a}$$

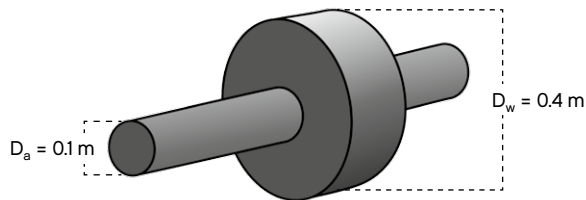

The mechanical advantage of this wheel and axle is 4:1 or 4 if the effort is applied to the axle. Meaning four times an increase in speed and distance, but at the same time a decrease in force by four times.

If the effort is applied to the wheel the mechanical advantage is 1:4, meaning a four times decrease in speed and distance, but four times increase in force.

 **Hint:**



The diameter of large LEGO® wheels are 43.2 mm ( $\approx 1.7 \text{ in}$ ).



The diameter of LEGO axles are 4.7 mm ( $\approx 0.18 \text{ in}$ ).

**B1**

This model shows a cart with split axles. It is very easy to steer both when driving in a straight line or when following zigzag patterns involving sharp turns. The split axles allow the wheels to turn at different speeds.

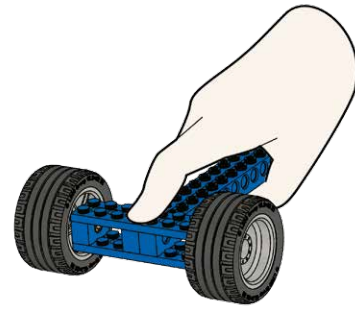
**B2**

This model shows a cart with fixed axles. It is very easy to steer when driving in a straight line. However, it is hard to steer when following zigzag patterns involving sharp turns as the wheels cannot turn at different speeds. One wheel will always skid when turning corners.

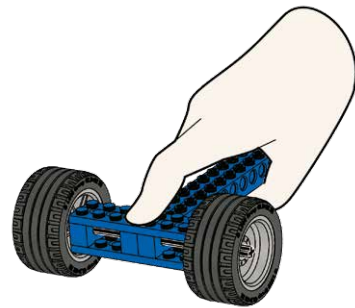
**B3**

This model shows a cart with a steering system. It is very easy to steer both when driving in a straight line or when following zigzag patterns involving sharp turns. The split axles allow the wheels to turn at different speeds and the steering wheel provides good control.

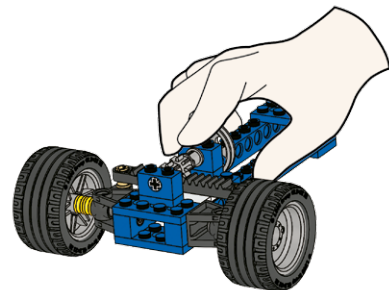



**B4**

This model shows a universal joint. When the handle is turned the rotary motion is transmitted through the universal joint at an angle to the output. The speed ratio between input and output is 1:1.

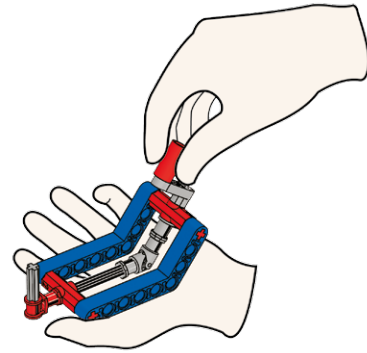
**B5**

The mechanical advantage of a LEGO® wheel and axle is 9.2. Depending on whether you are using the effort to turn the wheel or axle.



# Pulley

Student Worksheet

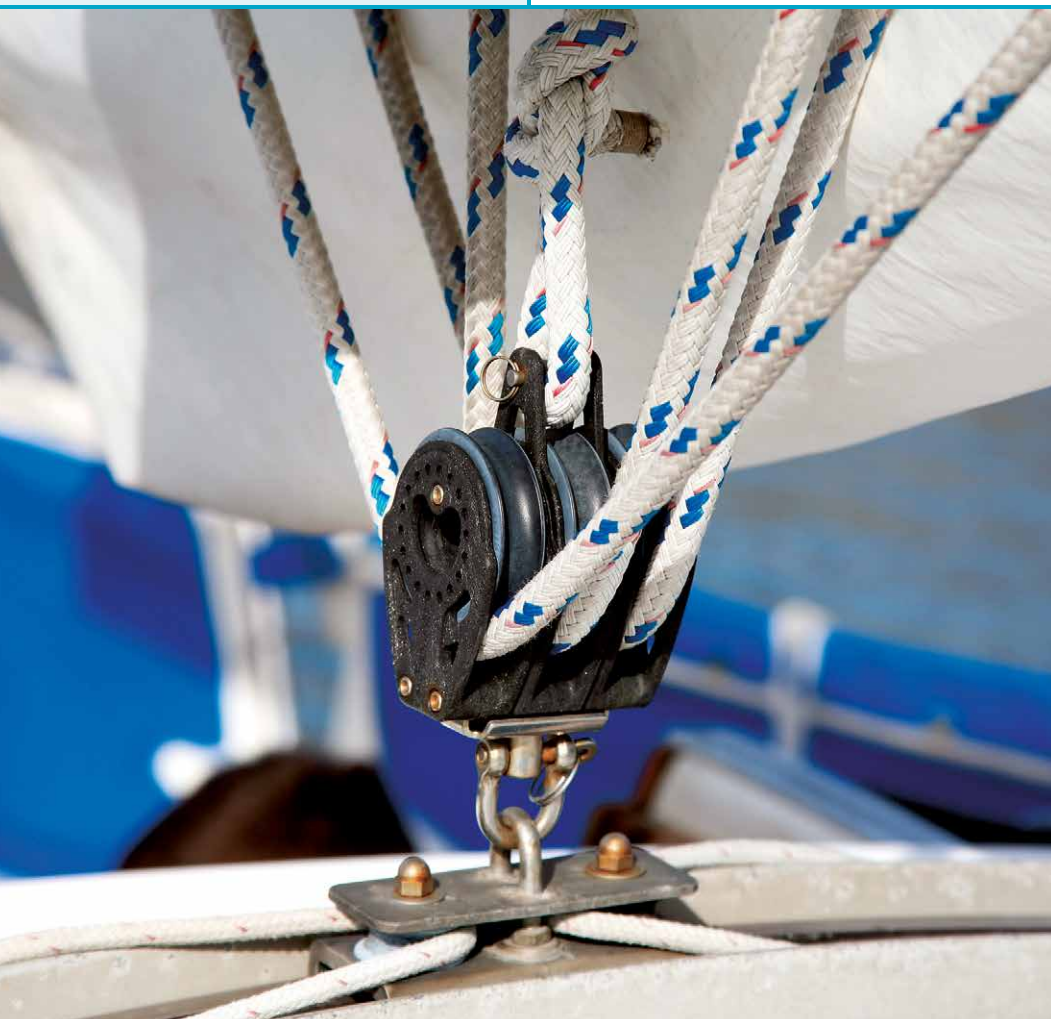
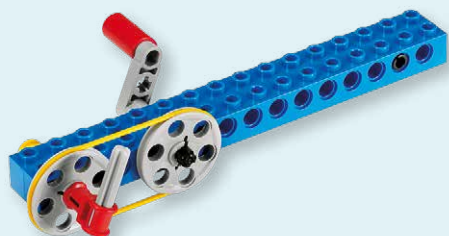

## Simple Machines: Pulley

Pulleys are wheels that are moved by ropes, chains or belts around their rims.

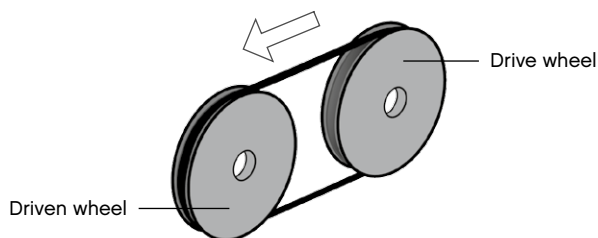

In a belt driven pulley a continuous belt joins two pulley wheels. The wheel to which an external force is applied (effort) is called the drive wheel, and the other the driven wheel. The drive pulley wheel provides the input force and the driven pulley wheel delivers the output force. When the drive wheel turns the belt moves and causes the driven wheel to turn in the same direction. If the drive wheel is smaller than the driven wheel, the driven wheel will turn more slowly than the drive wheel.

Belt driven pulleys rely on belt friction to transmit motion. If the belt is too tight the belt will create wasteful friction forces on the pulley axle and bearing. If too loose the belt will slip and the effort is not used efficiently. Slip is an overload protection safety feature of belt-operated machinery.

For heavy lifting jobs; multiple pulley wheels can be combined into a lifting system that makes lifting heavy objects easier.

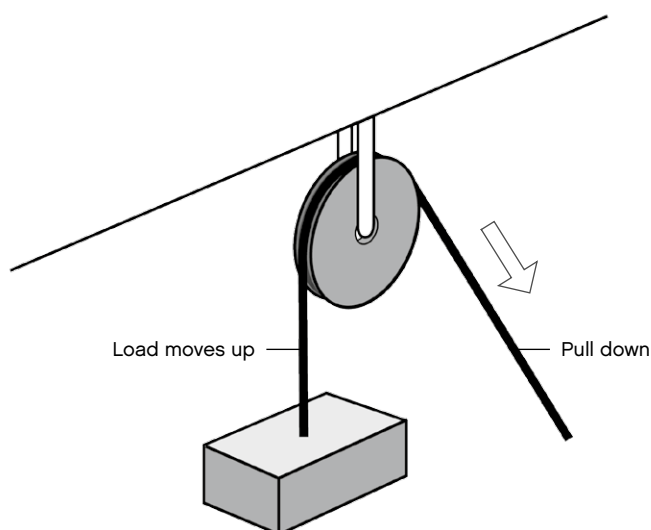

Using a single pulley to lift a load doesn't make it easier, but it changes the direction of motion without any gains in speed or required effort. It only allows you to lift a load up by the pulling of the rope. Pulleys can be either movable or fixed. The difference between fixed and movable pulleys are that fixed pulleys do not move up or down when the load is being moved. A fixed pulley is often fixed to an overhead beam or rafter and will only be able to rotate around its own axle. The use of multiple pulley wheels on one axle, in a lifting or dragging system, is called a Block and Tackle.

Common examples of pulleys are found in window blinds, curtains and flagpoles.

### Did you know?

Pulleys started the age of mass production in England, when they were produced at the beginning of the 19th century to supply the British Royal Navy with pulley blocks for their war ships during the Napoleonic Wars.

## The Mechanical Advantage of a Pulley

The advantage of a pulley lies in the trade-off between force and distance. In general, what you gain in useful force, you have to make up by traveling extra distance. The most accurate way of calculating the mechanical advantage of a belt driven pulley is to divide the inside diameter of the driven pulley wheel by the inside diameter of the drive pulley wheel. You can also compare the number of rotations of the driven pulley wheel to one rotation of the drive pulley wheel. However slip may affect the accuracy of your comparison.

$$\text{Mechanical advantage} = \frac{\text{Driven pulley diameter}}{\text{Driver pulley diameter}}$$

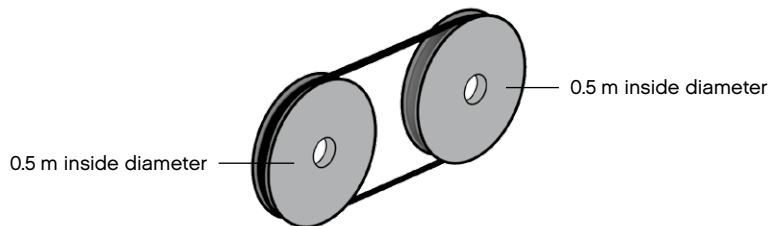

$$\text{Mechanical advantage} = \frac{0.5 \text{ m}}{0.5 \text{ m}}$$

$$\text{Mechanical advantage} = 1$$

There are two ways of determining the mechanical advantage of a pulley system. The simplest way to determine the mechanical advantage is counting the number of falls (or active lifting ropes) that are actually attached to the load. Alternatively, you can divide the effort distance by the load distance.

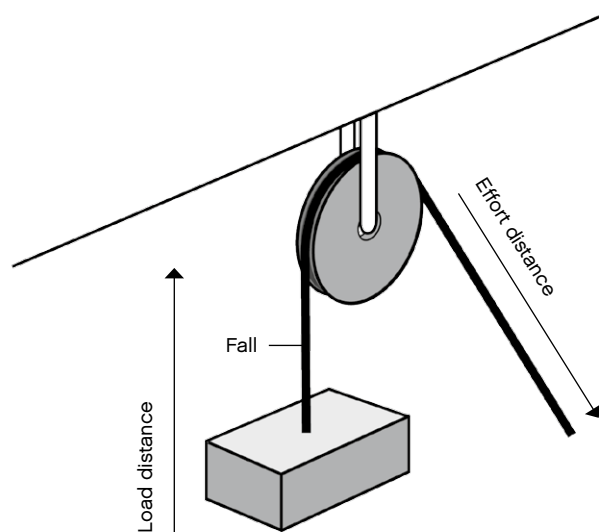

$$\text{Mechanical advantage} = 1$$

### Hint:



The inside diameter of a large pulley wheel is 22 mm (= 0.8 in).



The inside diameter of a small pulley wheel is 5.8 mm (= 0.22 in).

### Did you know?

In theory, you should be able to lift any object regardless of its weight using a huge block and tackle system and huge lengths of rope. However, due to an increase in friction, the system will eventually become inefficient to the point where it gives no mechanical advantage.

**C1****Build C1 book I, page 18**

Calculate the mechanical advantage. Then turn the handle while gently increasing your grip on the output pointer and explain what happens and why.

---



---



---

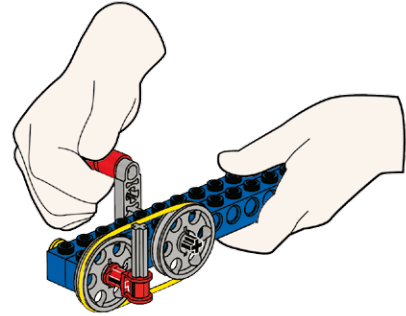

---

**C2****Build C2 book I, page 19**

Calculate the mechanical advantage. Then turn the handle while gently increasing your grip on the output pointer and explain what happens and why.

---



---



---

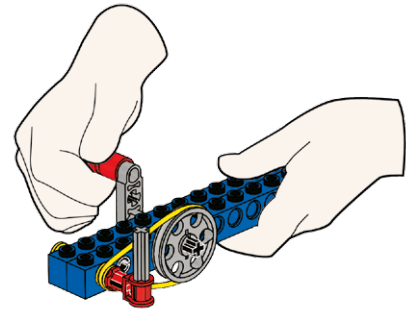

---

**C3****Build C3 book I, page 20**

Calculate the mechanical advantage. Then turn the handle while gently increasing your grip on the output pointer and explain what happens and why.

---



---



---



---

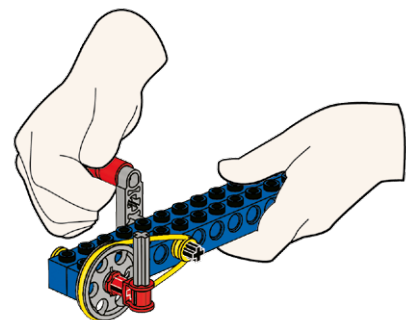

**C4****Build C4 book I, page 21**

Calculate the mechanical advantage. Then turn the handle while gently increasing your grip on the output pointer and explain what happens and why.

---



---



---

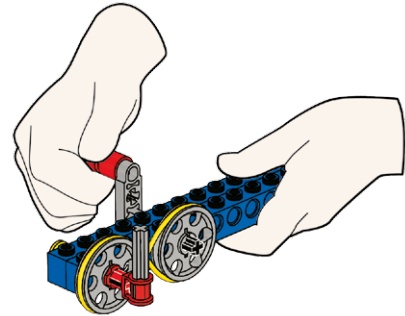

---

**C5****Build C5 book I, pages 22 to 23**

Calculate the mechanical advantage. Then turn the handle and explain what happens and why.

---



---



---

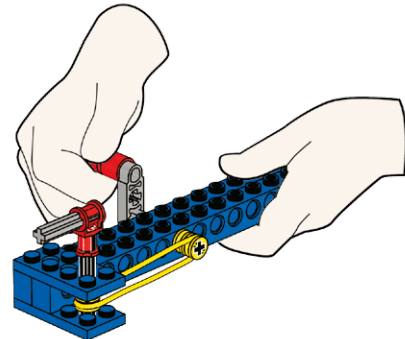

---

**C6****Build C6 book I, pages 24 to 25**

Calculate the mechanical advantage. Then turn the handle and explain what happens and why.

---



---



---



---

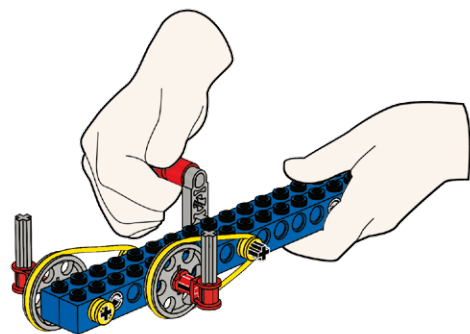

**C7**

**Build C7 book I, pages 26 to 27**

Calculate the mechanical advantage. Then turn the handle and explain what happens and why.

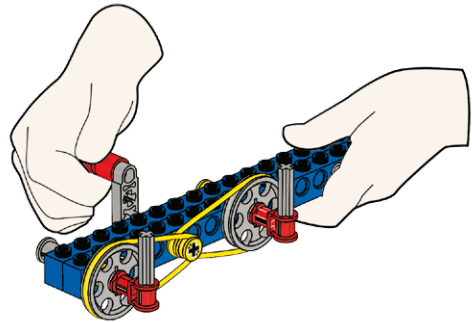

---



---



---



---

**C8**

**Build C8 book I, pages 28 to 31**

Lift the string to lift the load. Describe what happens.

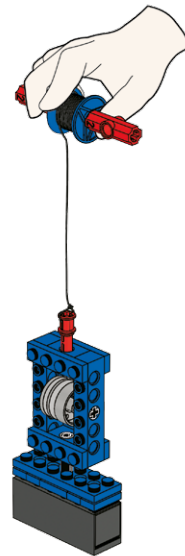

---



---



---



---

**C9**

**Build C9 book I, pages 32 to 35**

Calculate the mechanical advantage. Then pull the string to lift the load. Explain what happens and why.

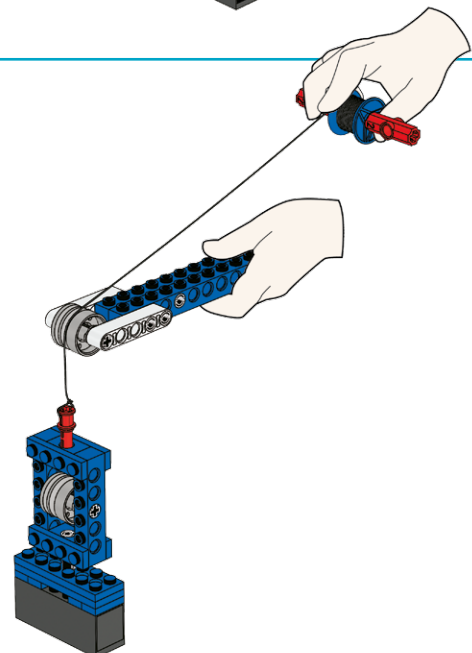

---



---



---



---

**C10**

**Build C10 book 1, page 36**

Calculate the mechanical advantage. Then pull the string to lift the load. Explain what happens and why.

---

---

---

---

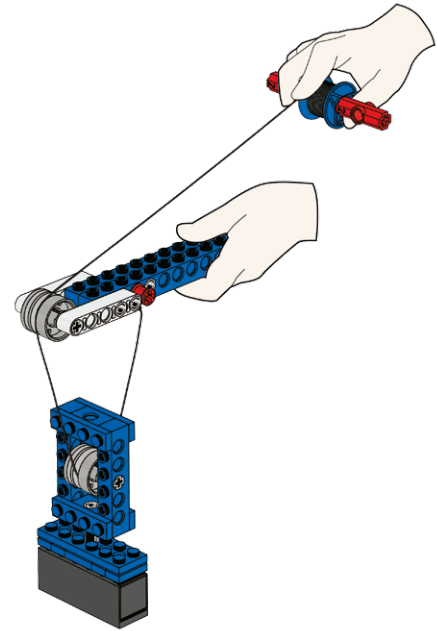



# Pulley

Teacher's Notes

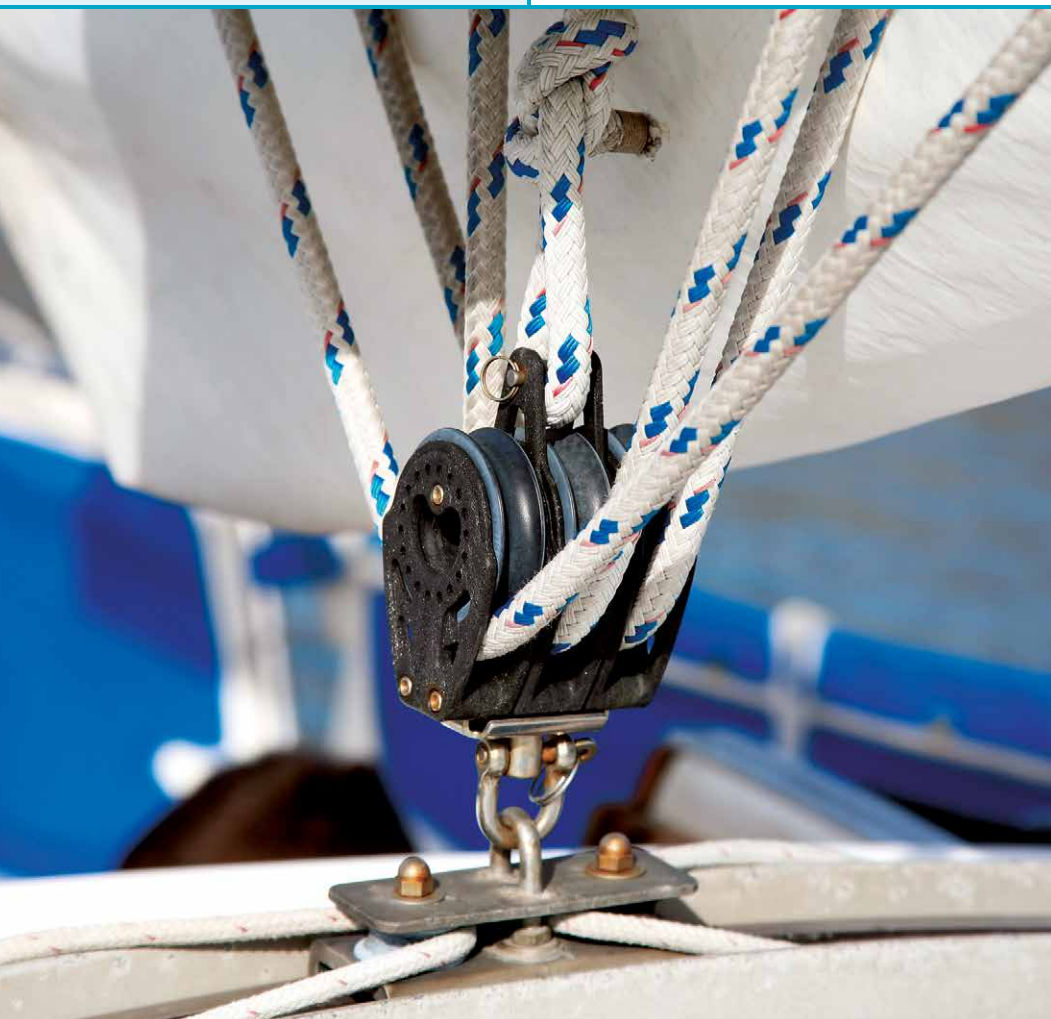
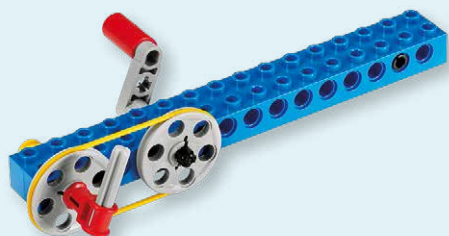

## Simple Machines: Pulley

Pulleys are wheels that are moved by ropes, chains or belts around their rims.

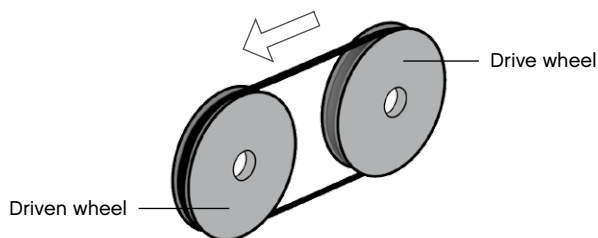

In a belt driven pulley a continuous belt joins two pulley wheels. The wheel to which an external force is applied (effort) is called the drive wheel, and the other the driven wheel. The drive pulley wheel provides the input force and the driven pulley wheel delivers the output force. When the drive wheel turns the belt moves and causes the driven wheel to turn in the same direction. If the drive wheel is smaller than the driven wheel, the driven wheel will turn more slowly than the drive wheel.

Belt driven pulleys rely on belt friction to transmit motion. If the belt is too tight the belt will create wasteful friction forces on the pulley axle and bearing. If too loose the belt will slip and the effort is not used efficiently. Slip is an overload protection safety feature of belt-operated machinery.

For heavy lifting jobs; multiple pulley wheels can be combined into a lifting system that makes lifting heavy objects easier.

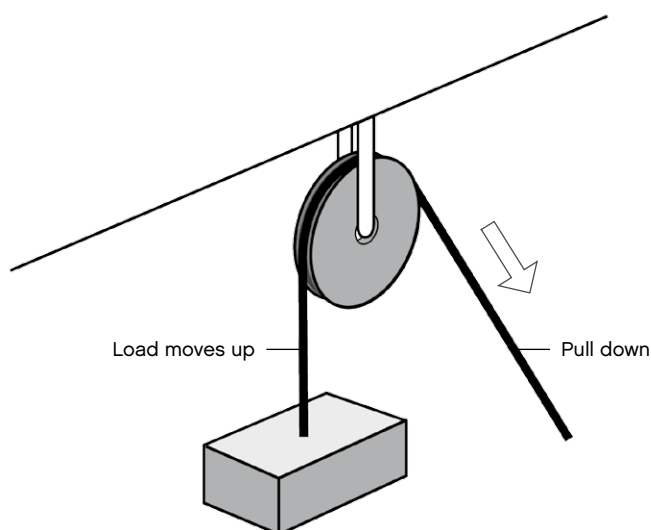

Using a single pulley to lift a load doesn't make it easier, but it changes the direction of motion without any gains in speed or required effort. It only allows you to lift a load up by the pulling of the rope. Pulleys can be either movable or fixed. The difference between fixed and movable pulleys are that fixed pulleys do not move up or down when the load is being moved. A fixed pulley is often fixed to an overhead beam or rafter and will only be able to rotate around its own axle. The use of multiple pulley wheels on one axle, in a lifting or dragging system, is called a Block and Tackle.

Common examples of pulleys are found in window blinds, curtains and flagpoles.

### Did you know?

Pulleys started the age of mass production in England, when they were produced at the beginning of the 19th century to supply the British Royal Navy with pulley blocks for their war ships during the Napoleonic Wars.

## The Mechanical Advantage of a Pulley

The advantage of a pulley lies in the trade-off between force and distance. In general, what you gain in useful force, you have to make up by traveling extra distance. The most accurate way of calculating the mechanical advantage of a belt driven pulley is to divide the inside diameter of the driven pulley wheel by the inside diameter of the drive pulley wheel. You can also compare the number of rotations of the driven pulley wheel to one rotation of the drive pulley wheel. However slip may affect the accuracy of your comparison.

$$\text{Mechanical advantage} = \frac{\text{Driven pulley diameter}}{\text{Driver pulley diameter}}$$

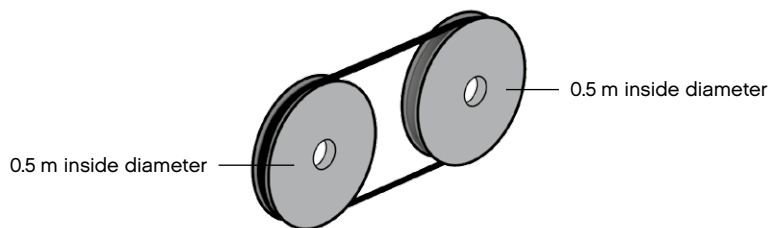

$$\text{Mechanical advantage} = \frac{0.5 \text{ m}}{0.5 \text{ m}}$$

$$\text{Mechanical advantage} = 1$$

There are two ways of determining the mechanical advantage of a pulley system. The simplest way to determine the mechanical advantage is counting the number of falls (or active lifting ropes) that are actually attached to the load. Alternatively, you can divide the effort distance by the load distance.

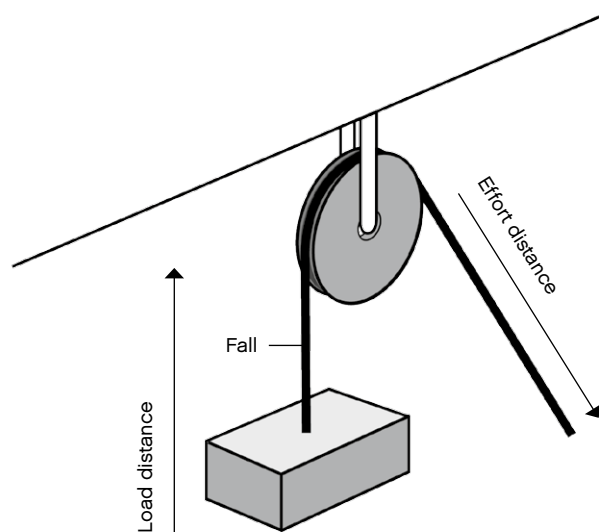

$$\text{Mechanical advantage} = 1$$

### Hint:



The inside diameter of a large pulley wheel is 22 mm (= 0.8 in).



The inside diameter of a small pulley wheel is 5.8 mm (= 0.22 in).

### Did you know?

In theory, you should be able to lift any object regardless of its weight using a huge block and tackle system and huge lengths of rope. However, due to an increase in friction, the system will eventually become inefficient to the point where it gives no mechanical advantage.

**C1**

This model has a mechanical advantage of 1. The model is a belt driven pulley where the speed and direction of the drive and driven pulley wheels are the same. A light grip on the output pointer will stop the driven pulley wheel from turning as this causes the belt to slip. The mechanical advantage of 1 represents the size ratio of the LEGO® components.

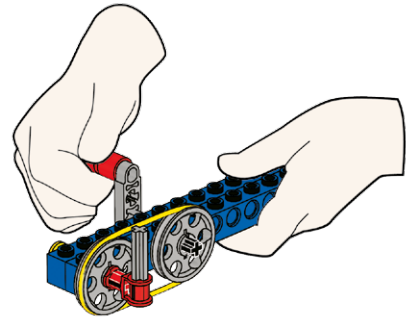
**C2**

This model has a mechanical advantage of 1:3.8. The model is a belt driven pulley where there is an increase in speed. The driven pulley wheel turns faster than the drive pulley wheel, but the output force is reduced plus the belt can more easily slip. The mechanical advantage of 1:3.8 represents the size ratio of the LEGO components.

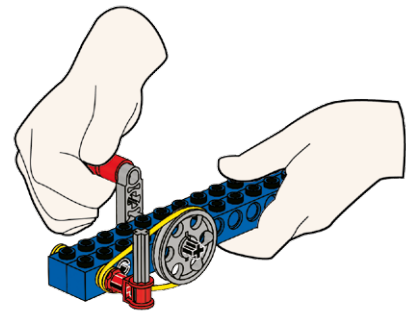
**C3**

This model has a mechanical advantage of 3.8:1. The model is a belt driven pulley where there is a decrease in speed. The driven pulley wheel turns slower than the drive pulley wheel. This increases the output force, but the belt slips with increasing load. The mechanical advantage of 3.8:1 represents the size ratio of the LEGO components.

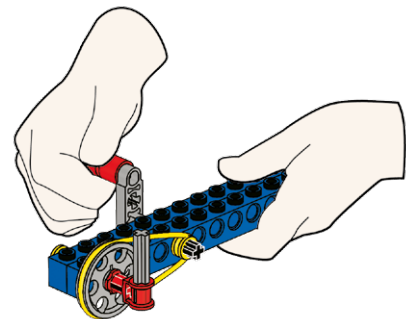

**C4**

This model has a mechanical advantage of 1. The model is a belt driven pulley where the speed of the drive and driven pulley wheels are the same, but they turn in opposite directions because the belt is crossed.

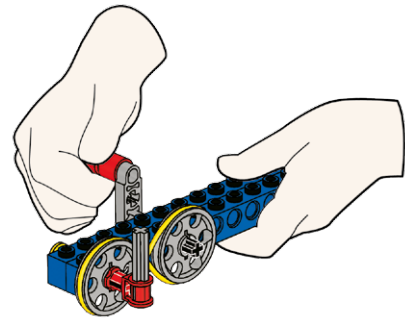
**C5**

This model has a mechanical advantage of 1. The model is a belt driven pulley where the speed of the drive and driven pulley wheels are the same, but there is a change in the angle of motion caused by the twist in the belt.

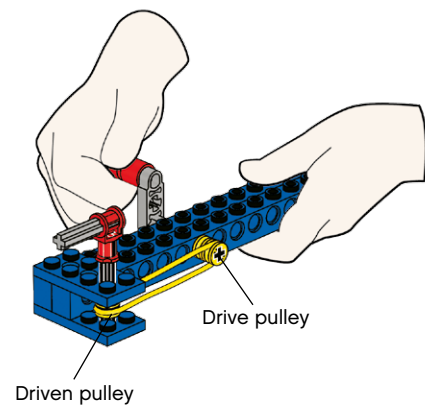
**C6**

This model has a mechanical advantage of 14.4:1. The model is a belt driven compound pulley where the speed of movement is reduced significantly, but the output force is greatly increased. The smaller drive pulley wheel causes the larger driven pulley wheel to move slower. The small drive pulley wheel on the same axle as the larger driven pulley wheel, becomes the drive pulley wheel of the second large driven pulley wheel.

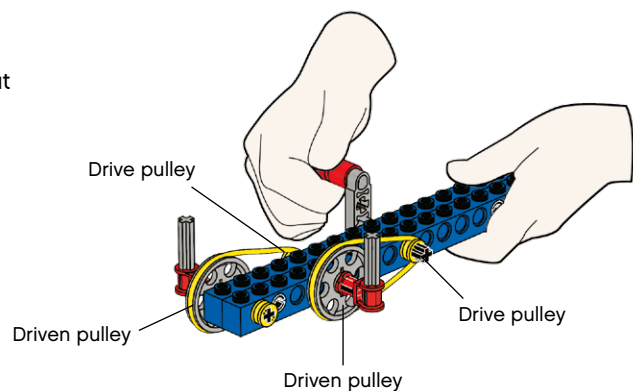

**C7**

This model has a mechanical advantage of 3.8:1. The model is a belt driven pulley where one drive pulley drives two driven pulley wheels, creating double output. The difference in size of the drive and driven pulley wheels causes a reduction in speed, but an increased output force.

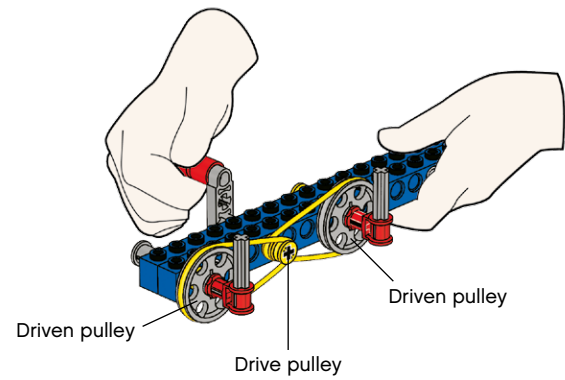
**C8**

This model has a mechanical advantage of 1. Meaning that the model generates no increase or reduction in needed effort, speed or distance. The full load of the LEGO® weight element is simply being lifted up or lowered.

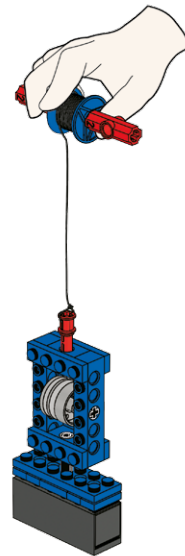
**C9**

This model has a mechanical advantage of 1, meaning that the model generates no increase or reduction of needed effort or speed. It only changes the direction of motion.

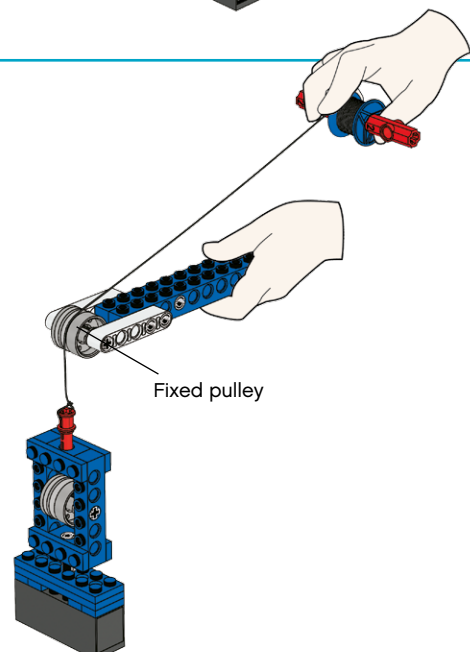

**C10**

This model has a mechanical advantage of 2, meaning that the model halves the effort needed to lift the load, but also reduces the speed at which the load is lifted. You must pull twice the length of string to lift the load.

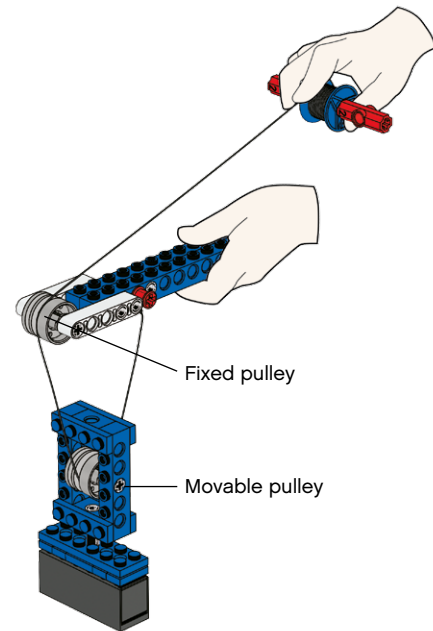

# Inclined Plane

Student Worksheet

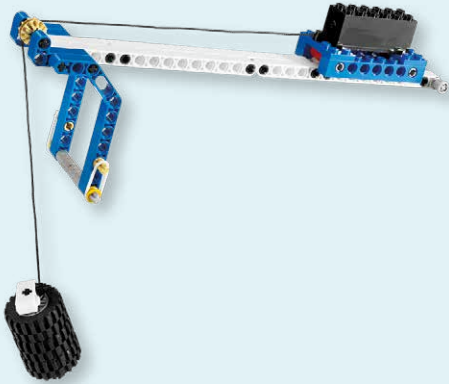



## Simple Machines: Inclined Plane

An inclined plane is a slanted surface used to raise objects, e.g. a ramp.

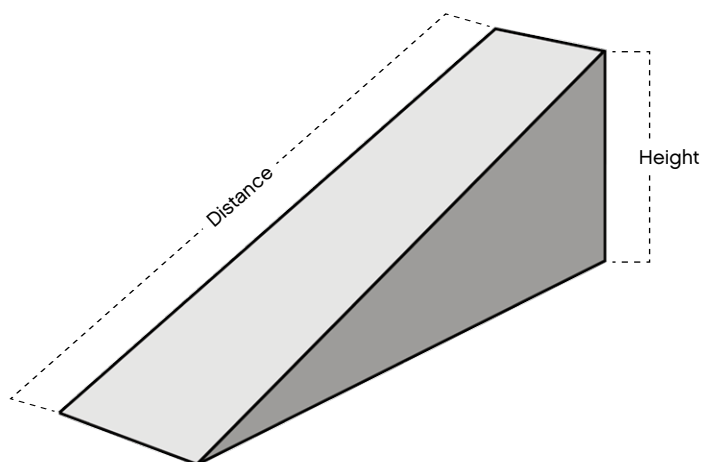

Using an inclined plane to raise an object to a given height, the object must be moved a longer distance, but with less effort needed, than if the object was to be raised straight up. It's a trade-off either to use a lot of effort to raise a given load a short distance straight upwards or to apply much less force to raise it gradually over the longer distance of an inclined plane.

Common examples of inclined planes are ramps, ladders and stairs.

### Did you know?

The advantage of using an inclined plane has been known and used for thousands of years. The ancient Egyptians used inclined planes made of earth to ease the transport of their giant stone blocks to the top of the pyramids.

## The Mechanical Advantage of an Inclined Plane

The mechanical advantage of an inclined plane describes the relationship between the length of the slope and the height of the inclined plane.

The mechanical advantage can be calculated using the following formula:

$$\text{Mechanical advantage} = \frac{\text{Distance load travels}}{\text{Height load is lifted}}$$

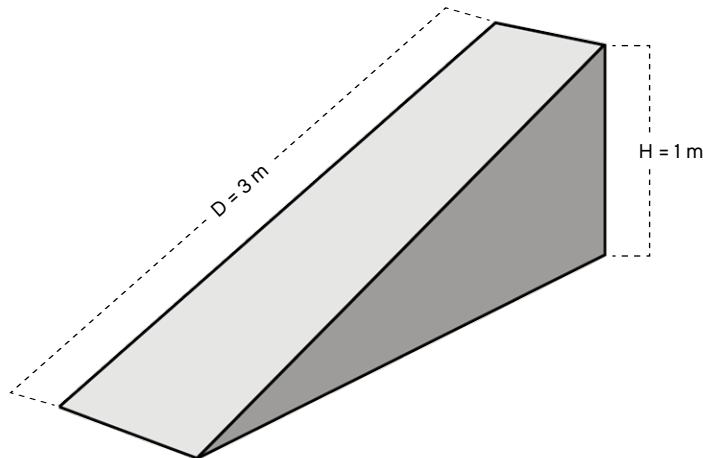

$$\text{Mechanical advantage} = \frac{3 \text{ m}}{1 \text{ m}}$$

$$\text{Mechanical advantage} = 3$$

Calculating the effort needed to raise a known load can be done using this formula:

$$\frac{\text{Load}}{\text{Effort}} = \frac{\text{Distance}}{\text{Height}}$$

Calculating the effort needed to move a load is also simple in theory. But in practice friction between the load and the surface of the ramp can affect the effort forces greatly.

**Did you know?**  
The mechanical advantage of straight vertical lift will always be 1. Meaning you would have to raise the entire load without any kind of mechanical advantage.

**D1**

**Build D1 book II, pages 2 to 12**

Calculate the mechanical advantage. Then let go of the load. Explain what happens and why.

---



---



---



---

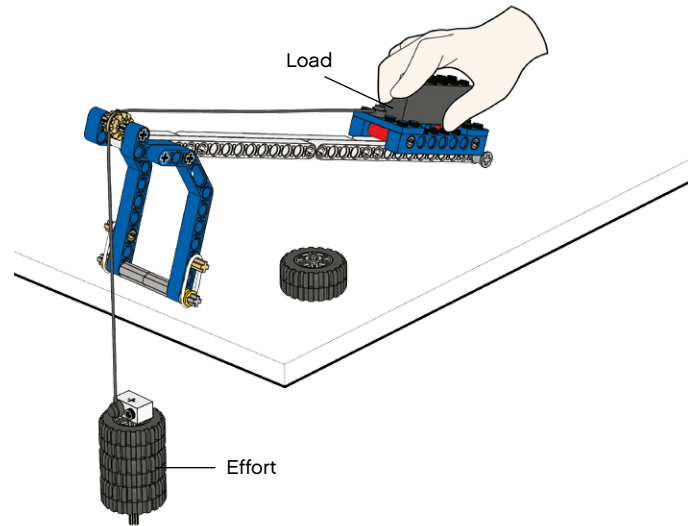

**D2**

**Build D2 book II, pages 13 to 15**

Calculate the mechanical advantage. Then let go of the load. Explain what happens and why.

---



---



---



---

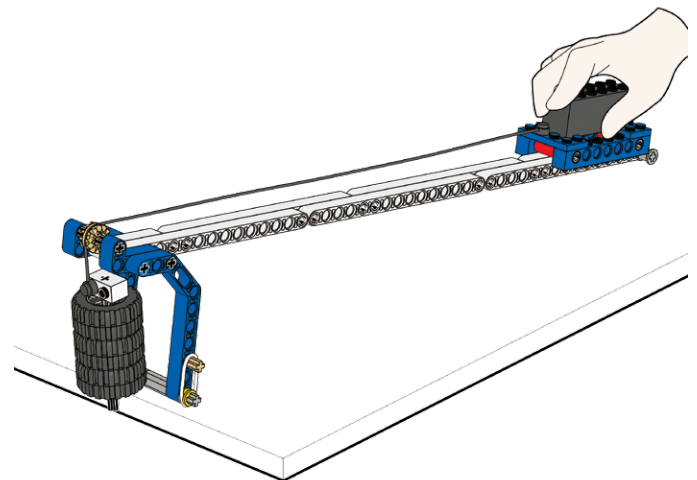

# Inclined Plane

Teacher's Notes

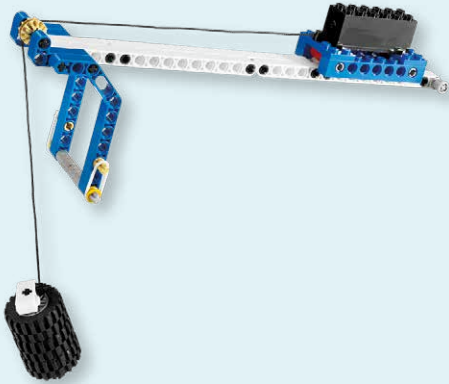

## Simple Machines: Inclined Plane

An inclined plane is a slanted surface used to raise objects, e.g. a ramp.

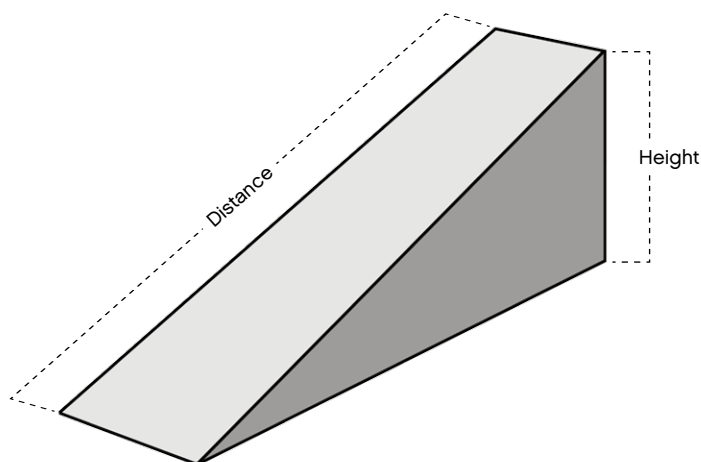

Using an inclined plane to raise an object to a given height, the object must be moved a longer distance, but with less effort needed, than if the object was to be raised straight up. It's a trade-off either to use a lot of effort to raise a given load a short distance straight upwards or to apply much less force to raise it gradually over the longer distance of an inclined plane.

Common examples of inclined planes are ramps, ladders and stairs.

### Did you know?

The advantage of using an inclined plane has been known and used for thousands of years. The ancient Egyptians used inclined planes made of earth to ease the transport of their giant stone blocks to the top of the pyramids.

## The Mechanical Advantage of an Inclined Plane

The mechanical advantage of an inclined plane describes the relationship between the length of the slope and the height of the inclined plane.

The mechanical advantage can be calculated using the following formula:

$$\text{Mechanical advantage} = \frac{\text{Distance load travels}}{\text{Height load is lifted}}$$

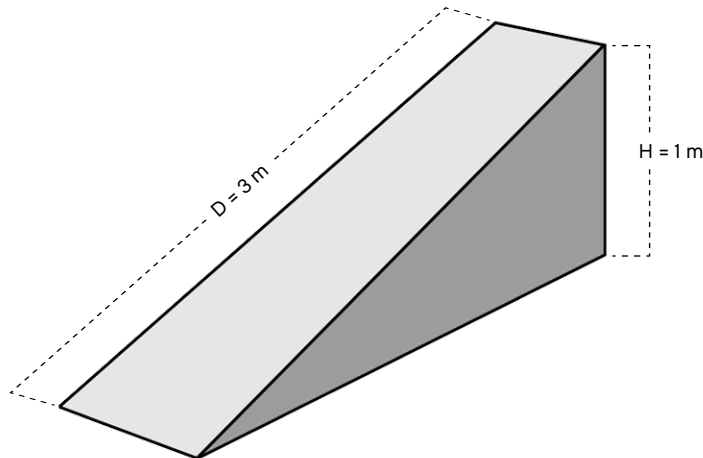

$$\text{Mechanical advantage} = \frac{3 \text{ m}}{1 \text{ m}}$$

$$\text{Mechanical advantage} = 3$$

Calculating the effort needed to raise a known load can be done using this formula:

$$\frac{\text{Load}}{\text{Effort}} = \frac{\text{Distance}}{\text{Height}}$$

Calculating the effort needed to move a load is also simple in theory. But in practice friction between the load and the surface of the ramp can affect the effort forces greatly.

**Did you know?**  
The mechanical advantage of straight vertical lift will always be 1. Meaning you would have to raise the entire load without any kind of mechanical advantage.

**D1**

This model shows a short inclined plane with a mechanical advantage of approximately 3. Nothing happens when the load is let go. The approximately 3N effort isn't enough to raise the approximately 6N load to the top of the inclined plane. This model thereby shows the difference between ideal and actual mechanical advantage. Under ideal circumstances an effort of more than 2N should be able to raise the load to the top, but the actual mechanical advantage is less due to friction. If another wheel is added as effort, it is able to raise the load.

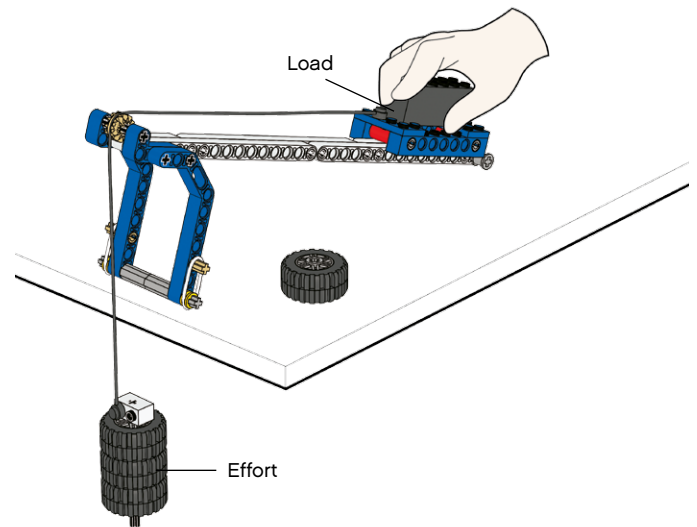
**D2**

This model shows a long inclined plane with a mechanical advantage of 4.5. Because of the added distance to this inclined plane, and hence the reduced angle of the ramp, the effort is able to raise the load to the top of the inclined plane.

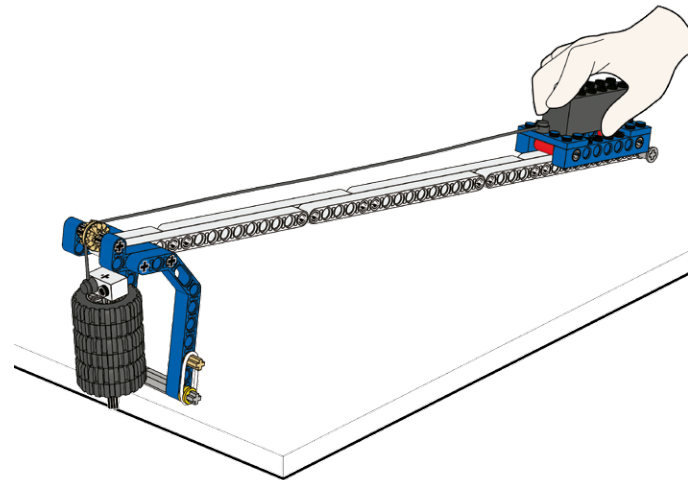

# Wedge

Student Worksheet

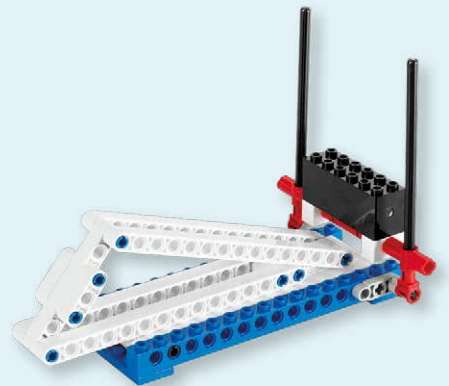



## Simple Machines: Wedge

A wedge is a modification of the inclined plane. Unlike an inclined plane a wedge can move.

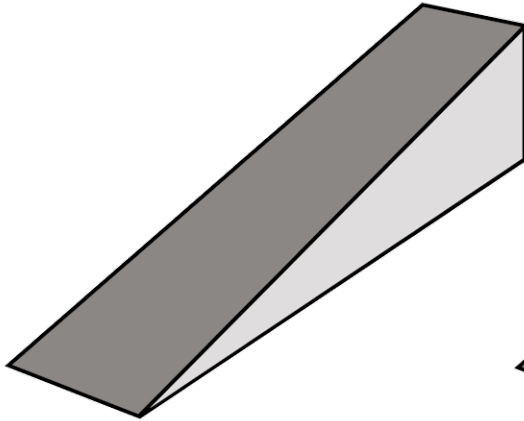

Single wedge

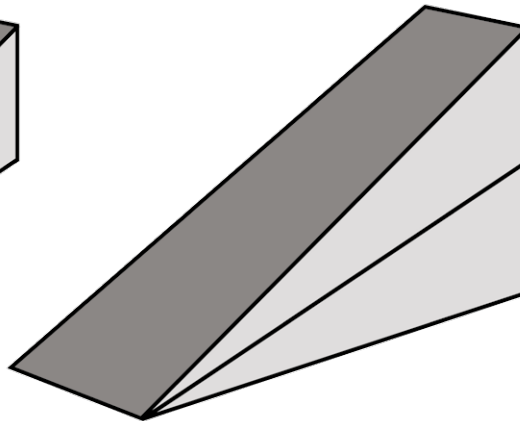

Double wedge

A wedge can have a single or two sloping surfaces. The effort you need depends on the relationship between the length and width of the wedge and consequently the sloping surface.

Common examples of wedges include axes, knives and doorstops.



### Did you know?

Wedges are used to split granite!

A simple device called a wedge and feather can split huge granite blocks.

## The Mechanical Advantage of a Wedge

The ideal mechanical advantage of a wedge describes the relationship between the length of the sloping side of the wedge and the height at the thickest end of the wedge. The mechanical advantage can be calculated using the following formula:

$$\text{Mechanical advantage} = \frac{\text{Slope}}{\text{Thickness}}$$

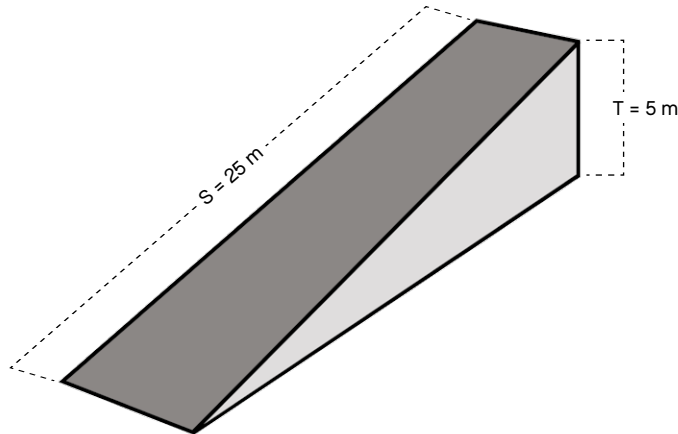

$$\text{Mechanical advantage} = \frac{25 \text{ m}}{5 \text{ m}}$$

$$\text{Mechanical advantage} = 5$$

**Hint:**  
The sharper the angle of the wedge, the more mechanical advantage it will have.

**E1****Build E1 book II, pages 16 to 25**

Calculate the mechanical advantage. Then push the wedge under the load. Explain what happens and why.

---



---



---

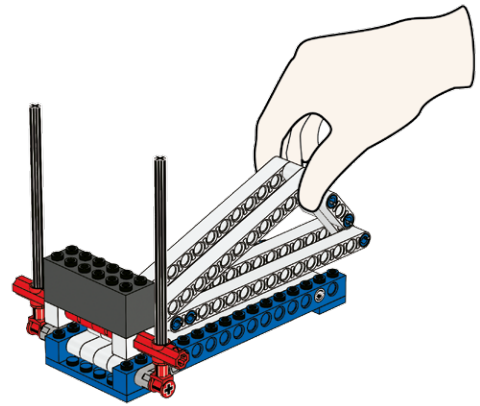

---

**E2**

Turn the wedge around and calculate the mechanical advantage. Then push the wedge under the load again. Explain what happens and why. Compare with the model above.

---



---



---



---

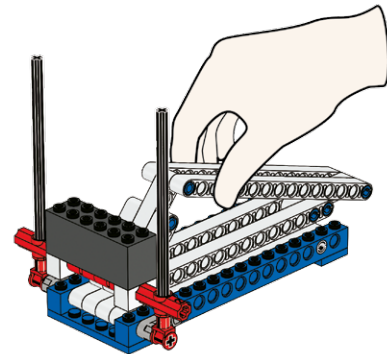

# Wedge

Teacher's Notes

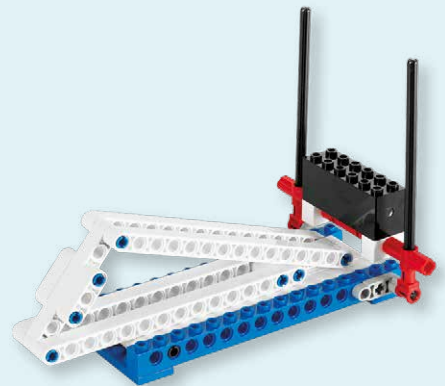

## Simple Machines: Wedge

A wedge is a modification of the inclined plane. Unlike an inclined plane a wedge can move.

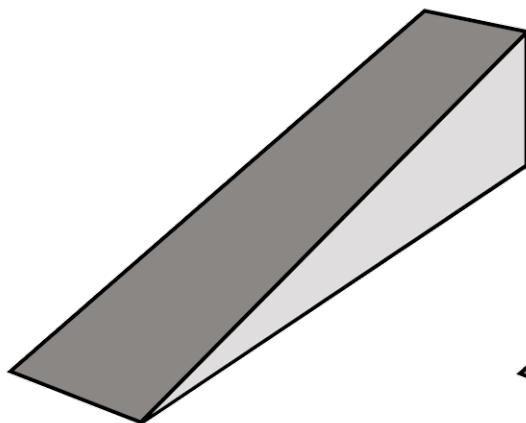

Single wedge

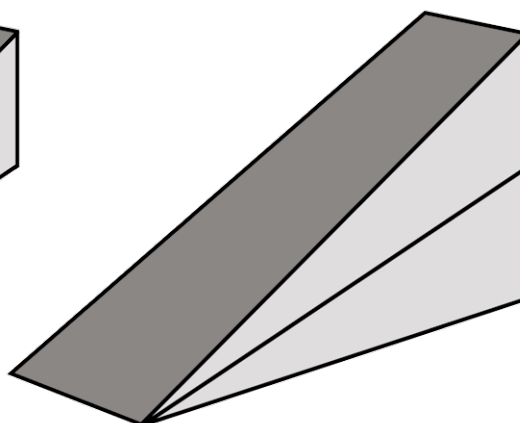

Double wedge

A wedge can have a single or two sloping surfaces. The effort you need depends on the relationship between the length and width of the wedge and consequently the sloping surface.

Common examples of wedges include axes, knives and doorstops.

### Did you know?

Wedges are used to split granite!

A simple device called a wedge and feather can split huge granite blocks.

## The Mechanical Advantage of a Wedge

The ideal mechanical advantage of a wedge describes the relationship between the length of the sloping side of the wedge and the height at the thickest end of the wedge. The mechanical advantage can be calculated using the following formula:

$$\text{Mechanical advantage} = \frac{\text{Slope}}{\text{Thickness}}$$

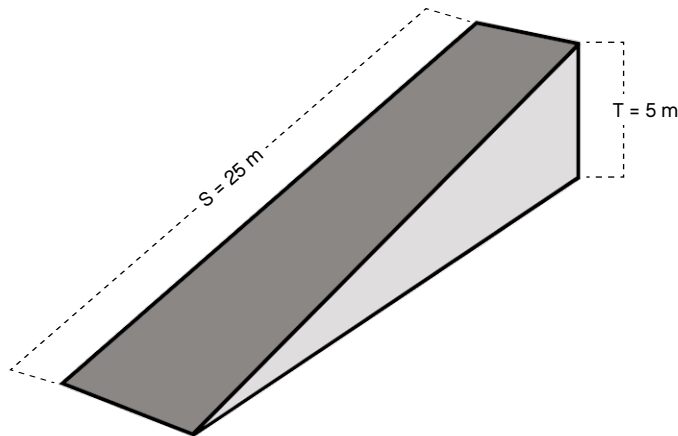

$$\text{Mechanical advantage} = \frac{25 \text{ m}}{5 \text{ m}}$$

$$\text{Mechanical advantage} = 5$$

**Hint:**  
The sharper the angle of the wedge, the more mechanical advantage it will have.

**E1**

This model shows a single wedge with a long sloping surface, which presents a mechanical advantage of approximately 3. The wedge needs a small effort to lift the load as the wedge has a small angle.

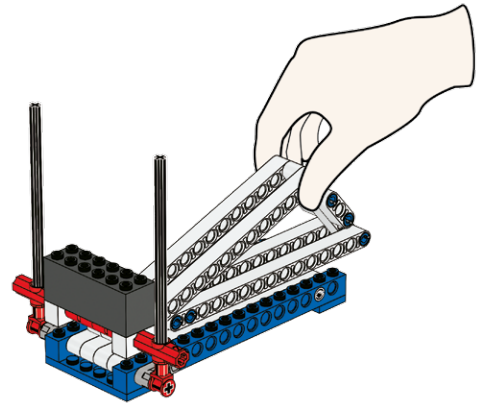
**E2**

This model shows a single wedge with a short sloping surface, which presents a mechanical advantage of 1.3. The steep angle of the sloping surface needs a greater effort to lift the load compared to the previous wedge. But it also travels a shorter distance.

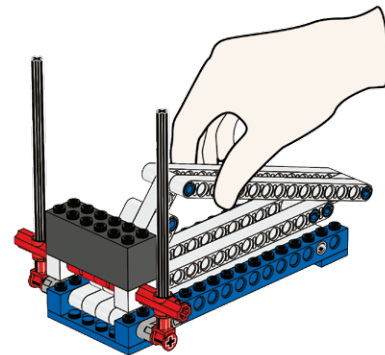

# Screw

Student Worksheet

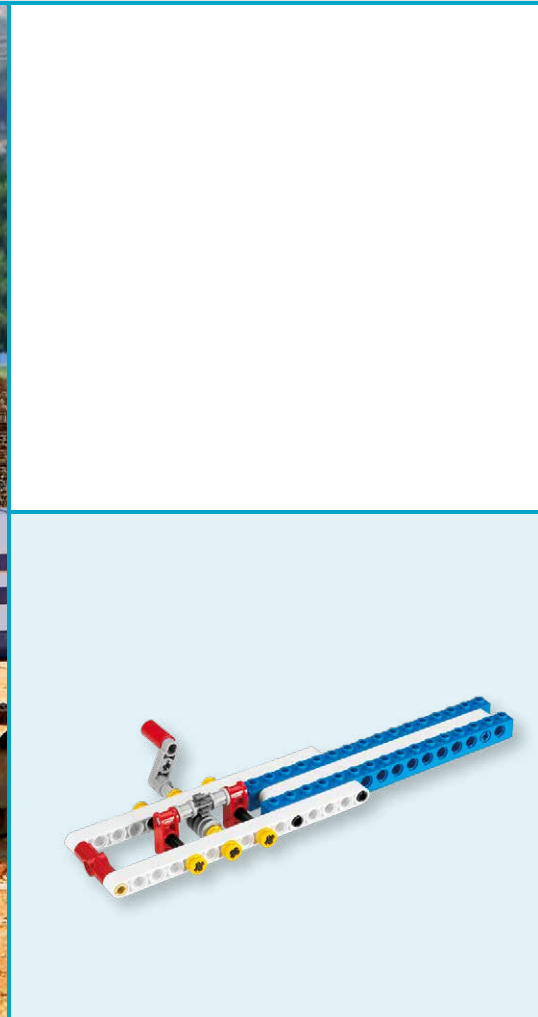
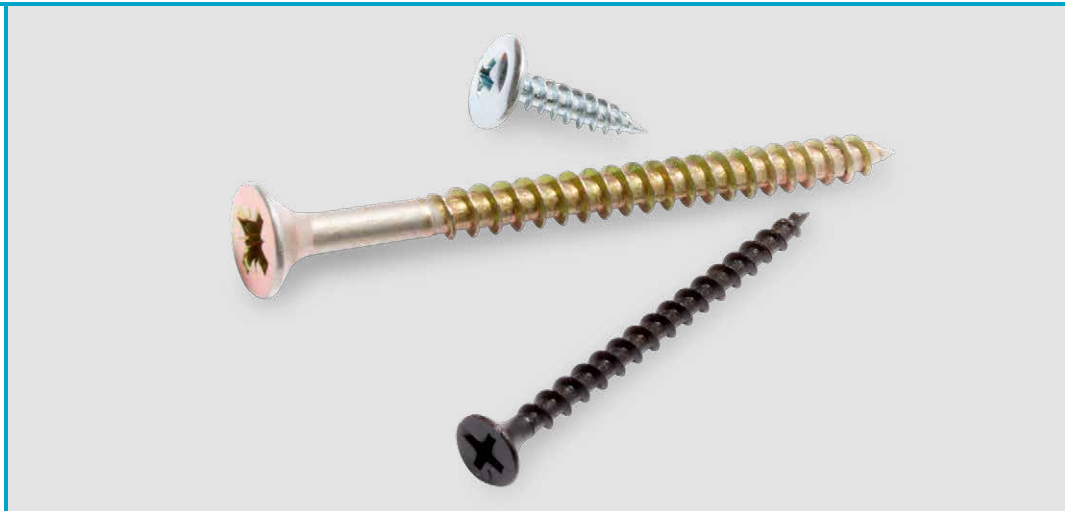



## Simple Machines: Screw

A screw is a modification of an inclined plane. The threads of a screw are like an inclined plane wrapped around a cylinder. The width of the treads are like the angle of an inclined plane.

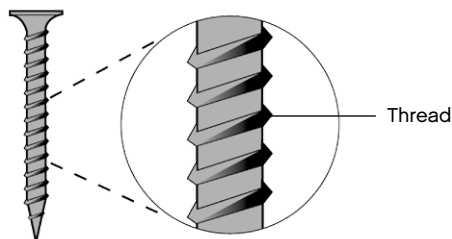

The finer the pitch of the screw, the more turns are required, but the less effort is needed to drive the screw in. The load is the friction and other forces exerted by the wood on the screw.

When a screw is screwed into a piece of wood, it is like rotating the long inclined plane through the load. The effort of a turning screwdriver is converted into a vertical effort that screws the screw into an object. How far the screw is able to move in one complete revolution is determined by the pitch of the screw.

The pitch is the number of threads per cm of screw. If a screw has 8 threads in a cm the screw has a pitch of  $1/8$ . A screw with a pitch of  $1/8$  will in one complete revolution move a distance of  $1/8$  of a cm into an object.

Common examples of screws are cork screws and drills.

**Did you know?**  
Archimedes, the Greek scientist, mathematician and inventor, used a screw as the basis for his screw-pump design to move water for irrigation in the 3rd century BC.

## The Mechanical Advantage of a Screw

The mechanical advantage of using a screw involves the spreading of the effort over a longer distance thereby allowing heavy loads to be overcome with a smaller amount of effort.

The mechanical advantage can be calculated using the following formula:

$$\text{Mechanical advantage} = \frac{\text{Distance effort moves}}{\text{Distance load moves}} = \frac{2\pi r}{\text{Pitch}}$$

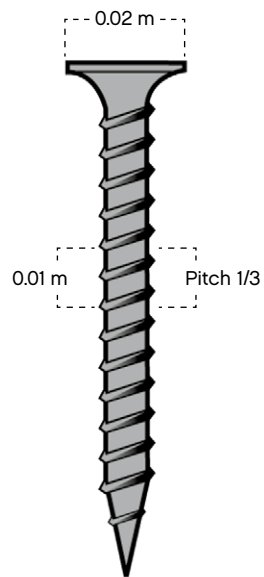

$$\text{Mechanical advantage} = \frac{2 \times \pi \times 0.02}{0.03}$$

$$\text{Mechanical advantage} = \text{approx. } 4$$

This means if you can twist your screwdriver with a force of 1N you can generate a force of 4N.

**F1**

**Build F1 book II, pages 26 to 32**

Turn the handle and explain what happens to the speed and the direction.

---

---

---

---

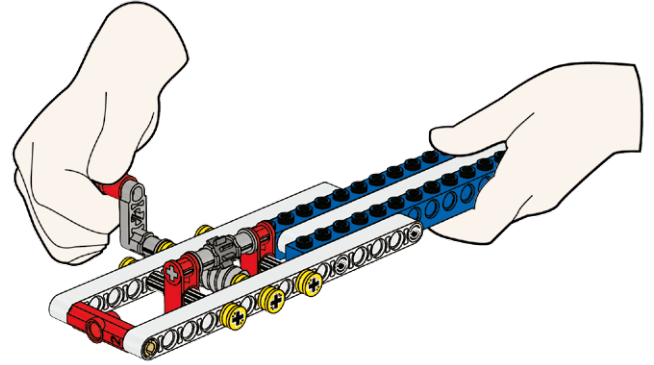

# Screw

Teacher's Notes

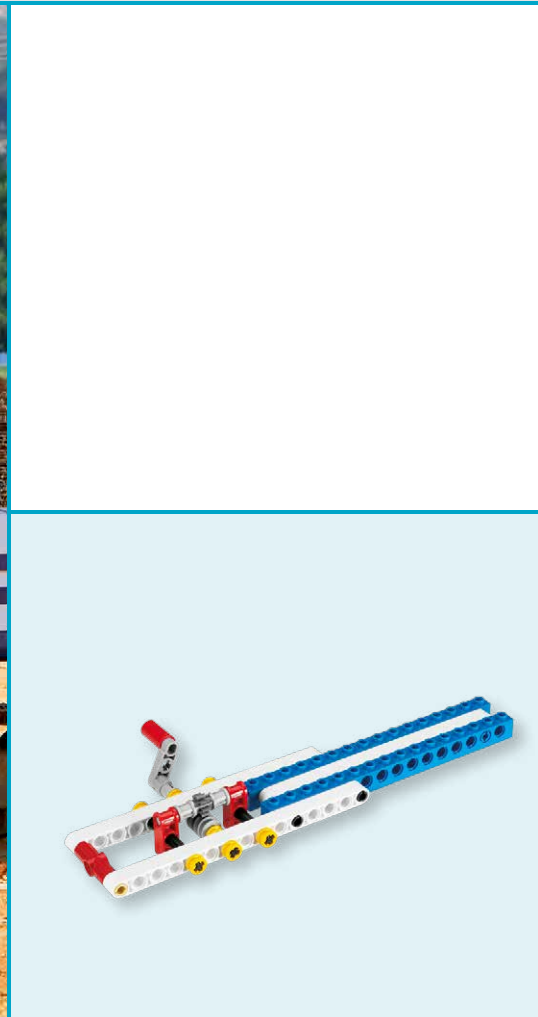

## Simple Machines: Screw

A screw is a modification of an inclined plane. The threads of a screw are like an inclined plane wrapped around a cylinder. The width of the treads are like the angle of an inclined plane.

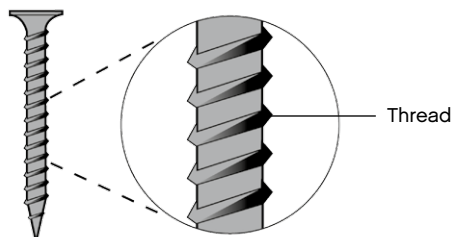

The finer the pitch of the screw, the more turns are required, but the less effort is needed to drive the screw in. The load is the friction and other forces exerted by the wood on the screw.

When a screw is screwed into a piece of wood, it is like rotating the long inclined plane through the load. The effort of a turning screwdriver is converted into a vertical effort that screws the screw into an object. How far the screw is able to move in one complete revolution is determined by the pitch of the screw.

The pitch is the number of threads per cm of screw. If a screw has 8 threads in a cm the screw has a pitch of  $1/8$ . A screw with a pitch of  $1/8$  will in one complete revolution move a distance of  $1/8$  of a cm into an object.

Common examples of screws are cork screws and drills.

### Did you know?

Archimedes, the Greek scientist, mathematician and inventor, used a screw as the basis for his screw-pump design to move water for irrigation in the 3rd century BC.

## The Mechanical Advantage of a Screw

The mechanical advantage of using a screw involves the spreading of the effort over a longer distance thereby allowing heavy loads to be overcome with a smaller amount of effort.

The mechanical advantage can be calculated using the following formula:

$$\text{Mechanical advantage} = \frac{\text{Distance effort moves}}{\text{Distance load moves}} = \frac{2\pi r}{\text{Pitch}}$$

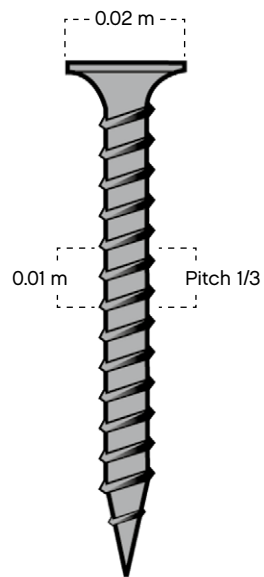

$$\text{Mechanical advantage} = \frac{2 \times \pi \times 0.02}{0.03}$$

$$\text{Mechanical advantage} = \text{approx. } 4$$

This means if you can twist your screwdriver with a force of 1N you can generate a force of 4N.

**F1**

This model uses the threads of the worm gear to demonstrate the principle of the screw. As the handle is turned the screw moves the gear across the screw at a 90° angle. The speed movement is significantly reduced.

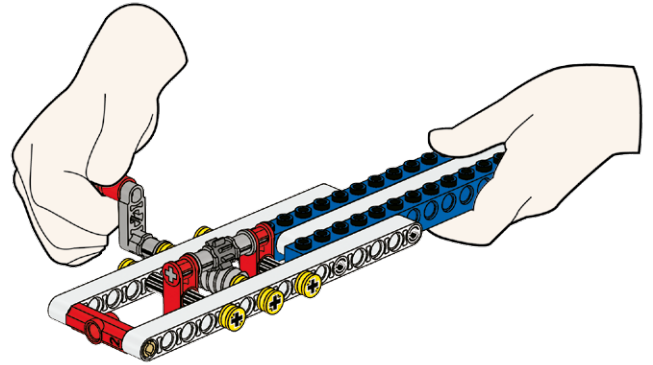

# Gear

Student Worksheet

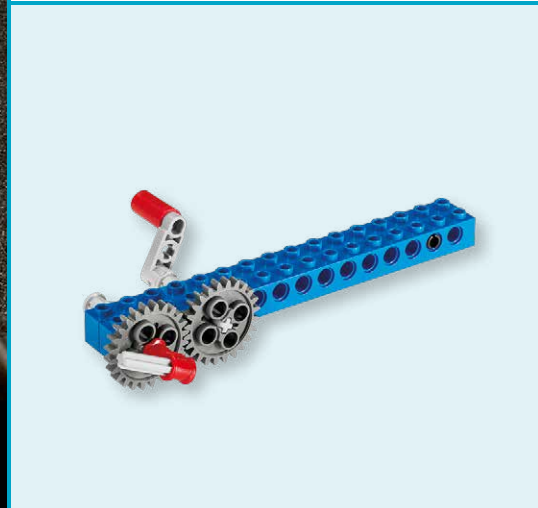
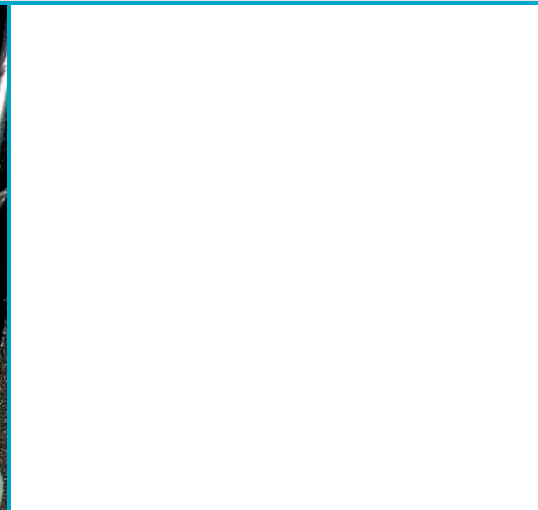
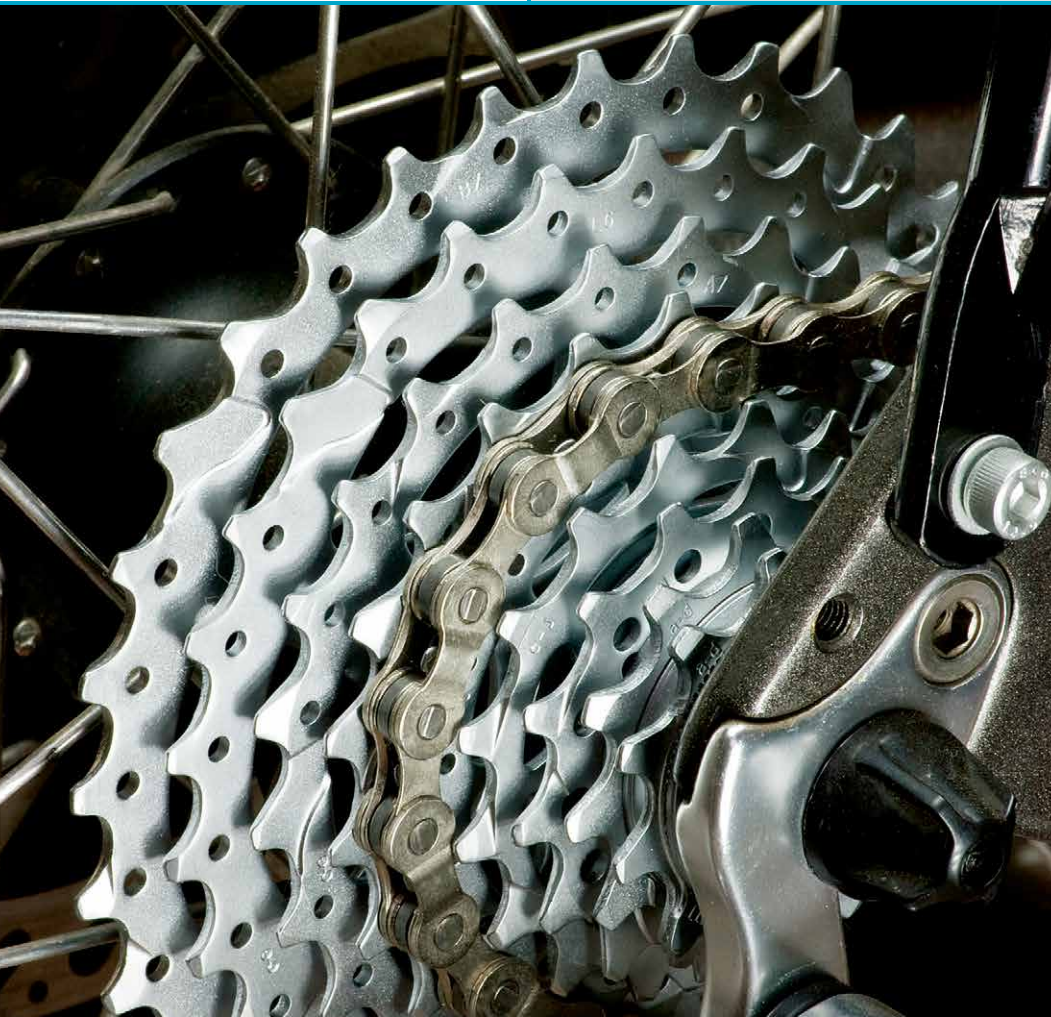
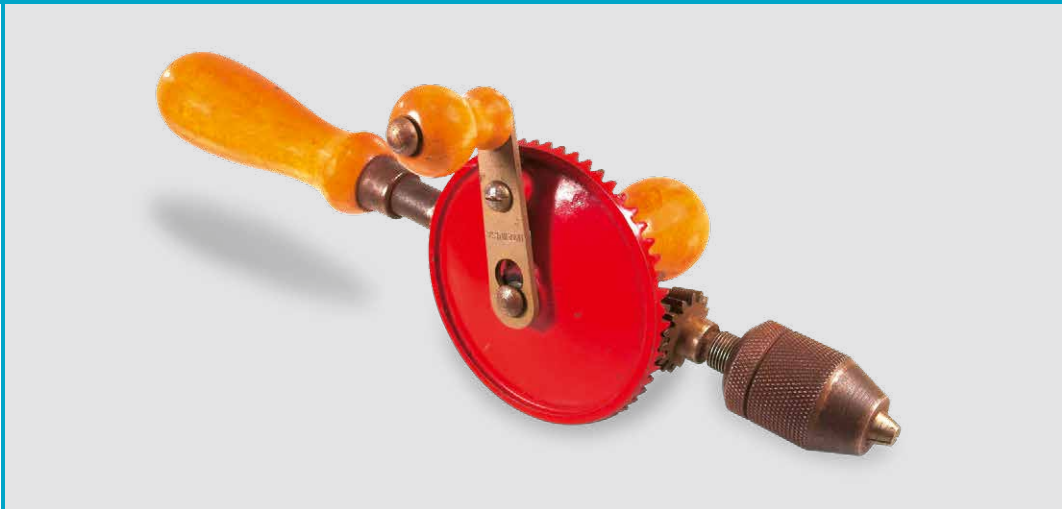



## Mechanisms: Gear

Gears are wheels with teeth that mesh with each other. Because the teeth lock together, they can efficiently transfer force and motion.

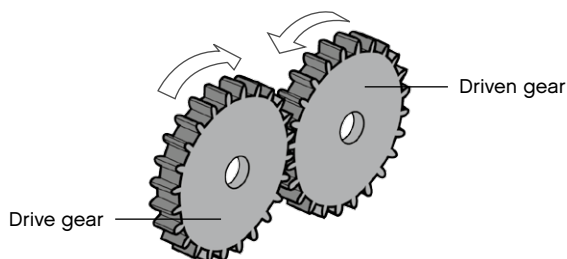

The drive gear is the gear that is turned by an outside effort, for instance your hand or an engine. Any gear that is turned by another gear is called a driven gear. The drive gear provides the input force and the driven gear delivers the output force.

Using a gear system can create change in speed, direction and force. But there are always advantages and disadvantages. For example, you can not both have more output force and an increase in speed at the same time.

To predict the ratio of which two meshed gears will move relative to each other, divide the number of teeth on the driven gear by the number of teeth on the drive gear. This is called the gear ratio. If a driven gear with 24 teeth is meshed with a drive gear with 48 teeth, there is a 1:2 gear ratio. Meaning that the driven gear will turn twice as fast as the drive gear.

Gears are found in many machines, where there is the need to control the speed of rotary movement and turning force. Common examples include power tools, cars and egg beaters!

### Did you know?

Not all gears are round. Some gears are square, triangular and even elliptical.

**G1**

**Build G1 book III, page 2**

Calculate the gear ratio. Then turn the handle and explain the speeds of the drive and the driven gears. Label the drive and driven gears.

---

---

---

---

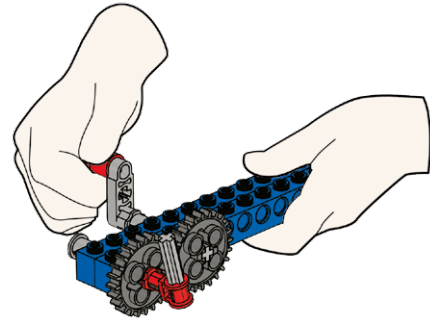

**G2**

**Build G2 book III, page 3**

Calculate the gear ratio. Then turn the handle and explain the speeds of the drive and the driven gears. Label the drive and driven gears.

---

---

---

---

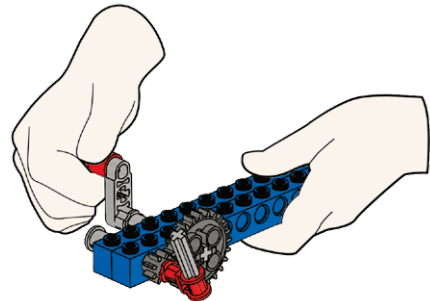

**G3**

**Build G3 book III, page 4**

Calculate the gear ratio. Then turn the handle and explain the speeds of the drive and the driven gears. Label the drive and driven gears.

---

---

---

---

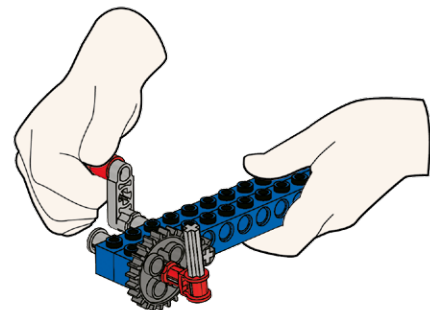

**G4**

**Build G4 book III, pages 5 to 6**

Calculate the gear ratio. Then turn the handle and explain the direction of the drive and the driven gears.

---

---

---

---

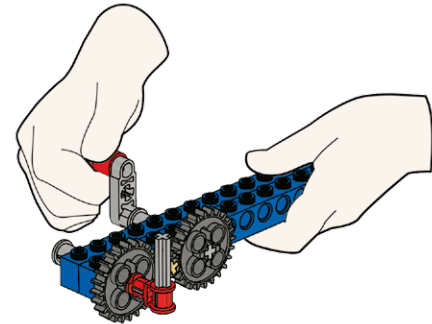

**G5**

**Build G5 book III, pages 7 to 8**

Calculate the gear ratio. Then turn the handle and explain the speeds of the drive and the driven gears.

---

---

---

---

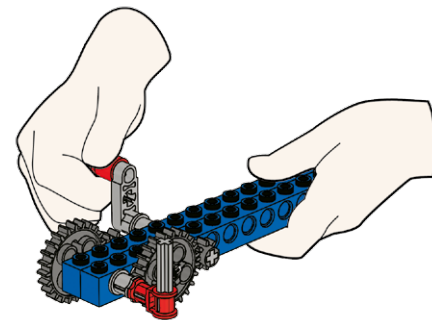

**G6**

**Build G6 book III, pages 9 to 10**

Turn the handle and explain the movement of the driven gear.

---

---

---

---

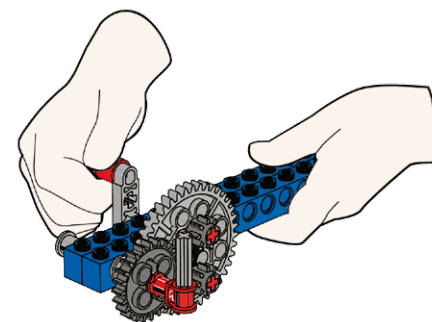

**G7**

**Build G7 book III, pages 11 to 14**

Calculate the gear ratio. Then turn the handle and explain what happens and why.

---



---



---



---

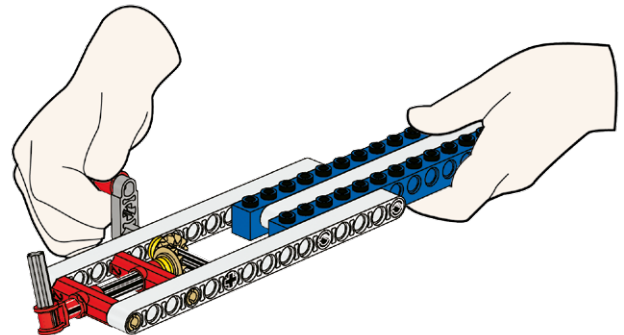

**G8**

**Build G8 book III, pages 15 to 18**

Turn the handle and explain what happens and why. What happens if you stop one of the output pointers. What happens if you stop both output pointers?

---



---



---



---

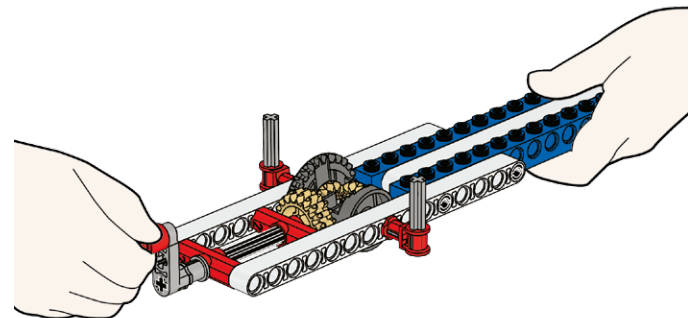

**G9**

**Build G9 book III, pages 19 to 22**

Turn the handle and explain what happens and why. What happens if you try turning the output pointer?

---



---



---



---

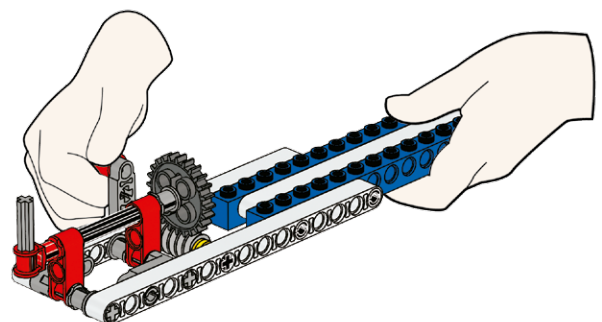

**G10**

**Build G10 book III, pages 23 to 25**

Turn the handle and explain what happens and why.

---

---

---

---

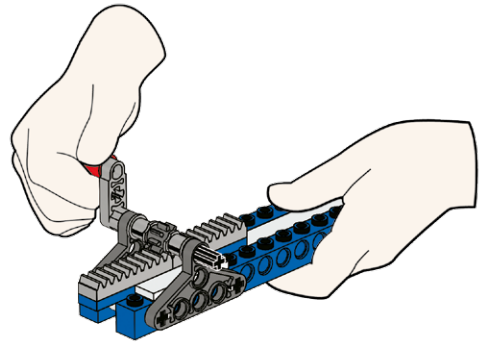

# Gear

Teacher's Notes

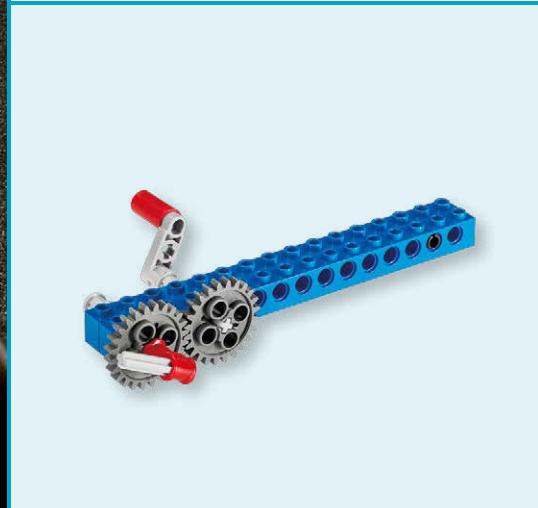
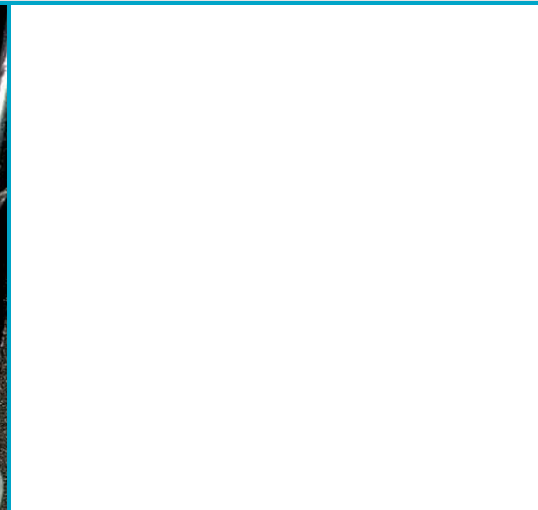
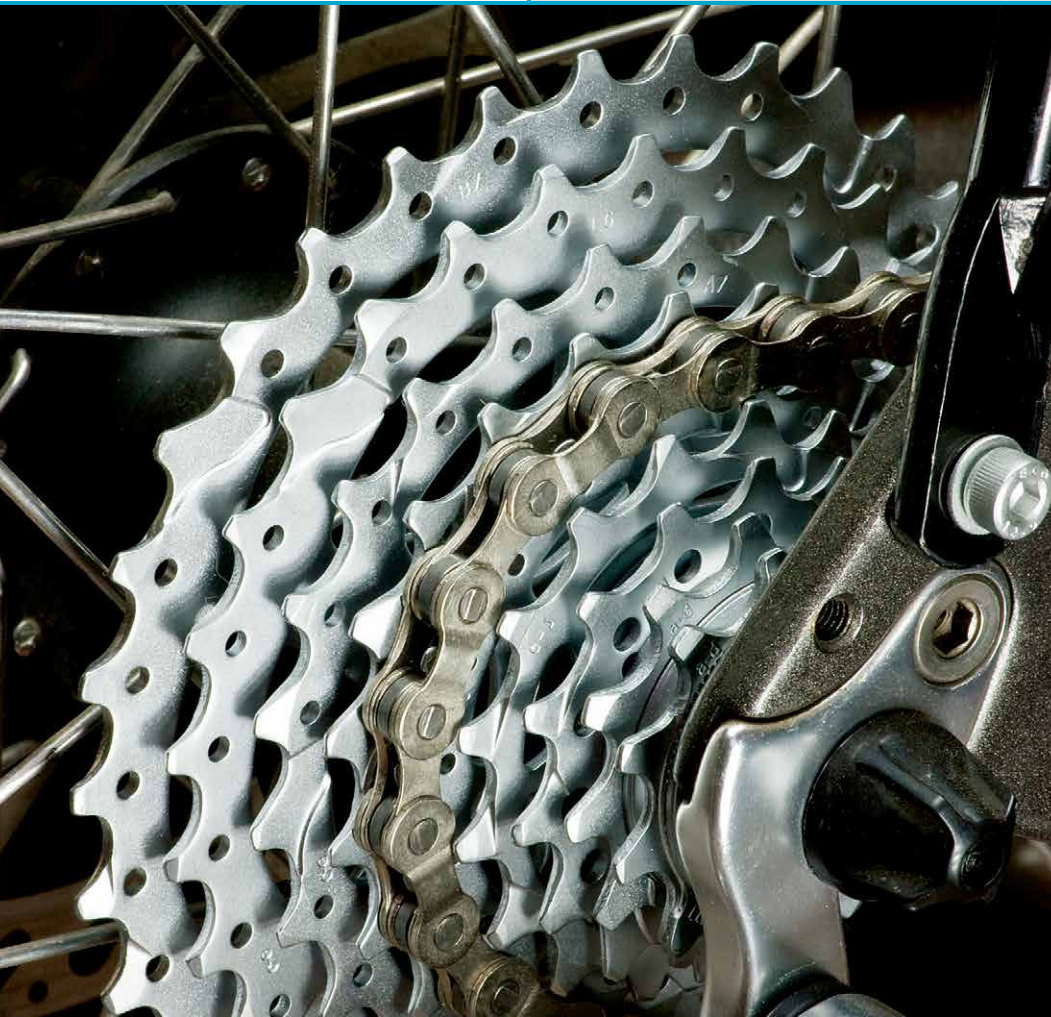
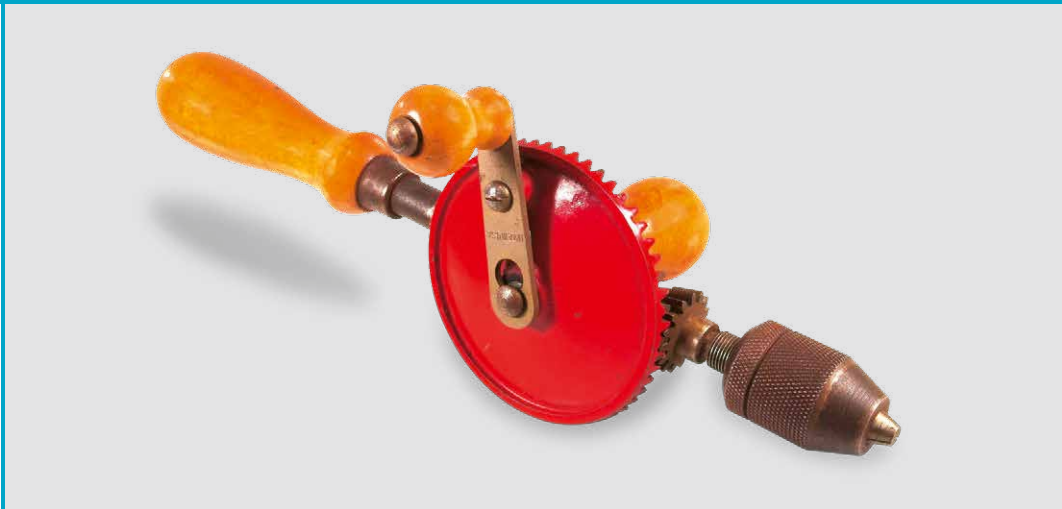

## Mechanisms: Gear

Gears are wheels with teeth that mesh with each other. Because the teeth lock together, they can efficiently transfer force and motion.

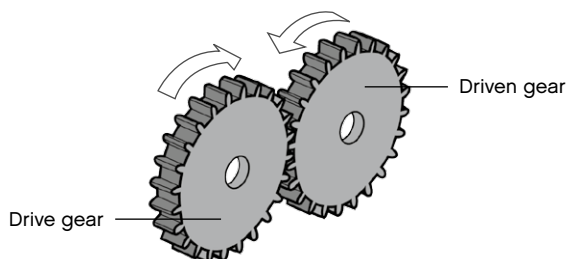

The drive gear is the gear that is turned by an outside effort, for instance your hand or an engine. Any gear that is turned by another gear is called a driven gear. The drive gear provides the input force and the driven gear delivers the output force.

Using a gear system can create change in speed, direction and force. But there are always advantages and disadvantages. For example, you can not both have more output force and an increase in speed at the same time.

To predict the ratio of which two meshed gears will move relative to each other, divide the number of teeth on the driven gear by the number of teeth on the drive gear. This is called the gear ratio. If a driven gear with 24 teeth is meshed with a drive gear with 48 teeth, there is a 1:2 gear ratio. Meaning that the driven gear will turn twice as fast as the drive gear.

Gears are found in many machines, where there is the need to control the speed of rotary movement and turning force. Common examples include power tools, cars and egg beaters!

### Did you know?

Not all gears are round. Some gears are square, triangular and even elliptical.

**G1**

This model has a 1:1 gear ratio. The speeds of the drive gear and the driven gears are the same, because they have the same number of teeth. The drive and driven gears turn in opposite directions.

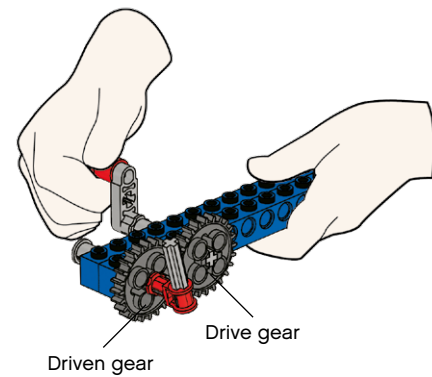
**G2**

This model has a 1:3 gear ratio. The larger drive gear turns the smaller driven gear, resulting in increased speed, but reduced output force. This is called gearing up.

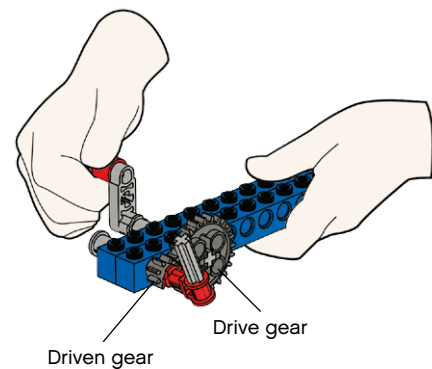
**G3**

This model has a 3:1 gear ratio. The smaller drive turns the larger driven gear, resulting in reduced speed, but increased output force. This is called gearing down.

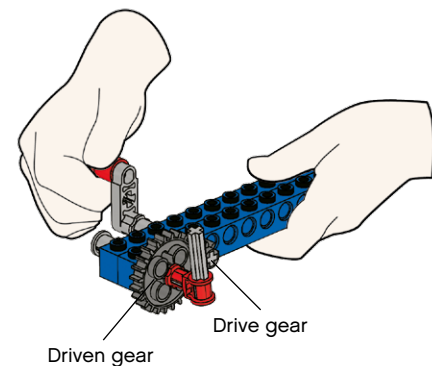



**G4**

This model has a 1:1 gear ratio. The small middle gear is an idler gear. The idler gear does not affect the gear ratio, speed or output force of either the drive or the driven gears. The drive and the driven gears turn in the same direction and at the same speed.

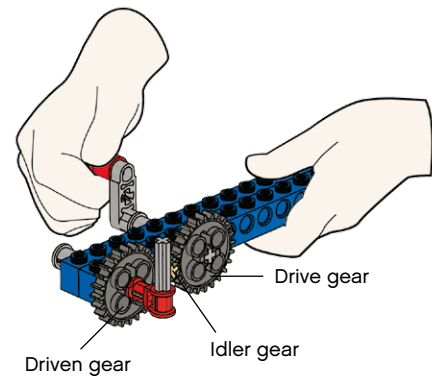
**G5**

This model shows a compound gearing with a 9:1 gear ratio. Because of this, the turning speed is significantly reduced and the output force is greatly increased. The smaller drive gear slowly turns the larger driven gear. The smaller gear on the same axle as the driven gear is now set in motion and is slowly turning the second large driven gear making it turn even more slowly.

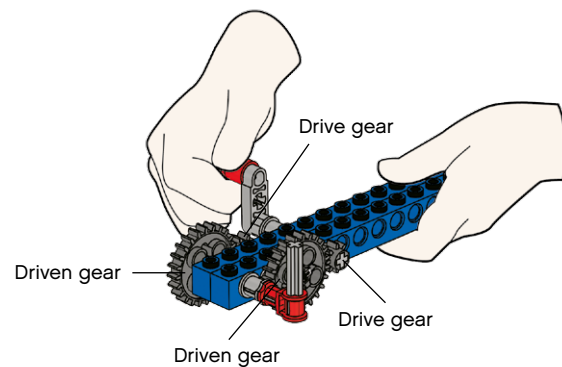
**G6**

This model shows a gearing set up for periodic movement e.g. the driven gear turns for a short while then stops for a moment. Speed is significantly reduced, as movement only occurs when the driven gear is meshed with one of the two drive gears.

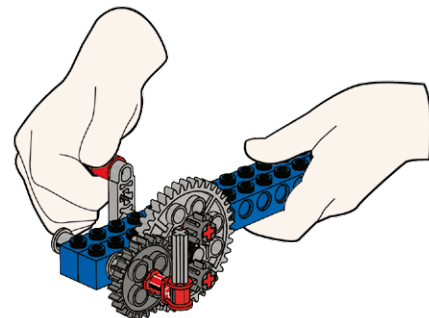

**G7**

This model shows an angle gearing with a 1:1 gear ratio. The two meshed bevel gears transfer the speed and force unchanged, but at an angle of 90°.

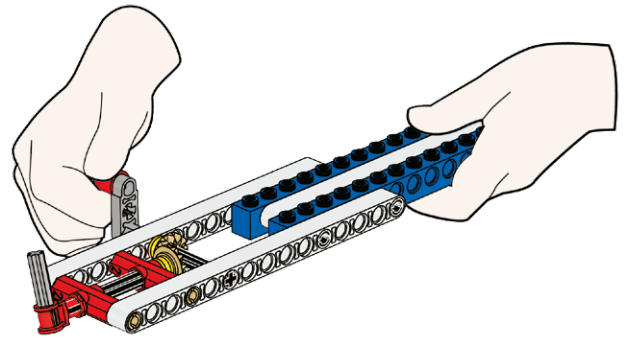
**G8**

This model shows a differential gearing with a gear ratio of either 28:20 or 7:10. The input force is transferred to two output forces at an angle of 90°. When one output pointer is stopped the other will double its original speed. When both output pointers are stopped the handle cannot be turned.

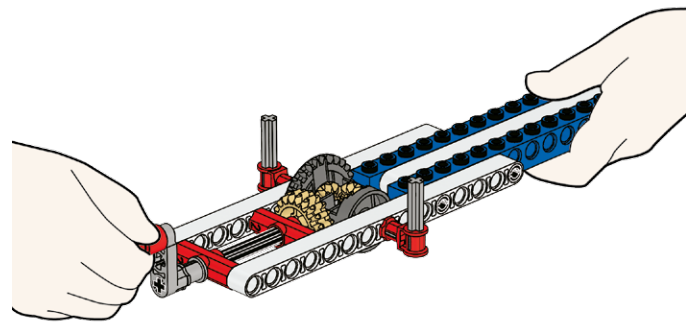
**G9**

This model shows a worm gear with a 24:1 gear ratio. It reduces speed significantly as it takes a complete turn of the worm gear to move the gear above by a single tooth. It changes direction by 90°. The output force is increased significantly. Worm gears can only be used as a drive gear.

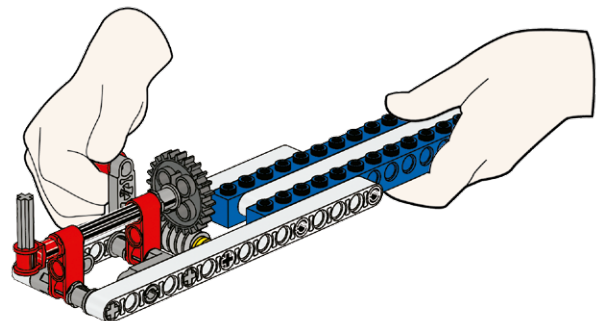

**G10**

This model shows a rack and pinion with a 1:1 gear ratio. Unlike the previous gears a rack and pinion can only be used for linear motion not rotary. When the handle is turned the gear rack moves forward or backwards depending on the rotational direction of the small gear (called a pinion).

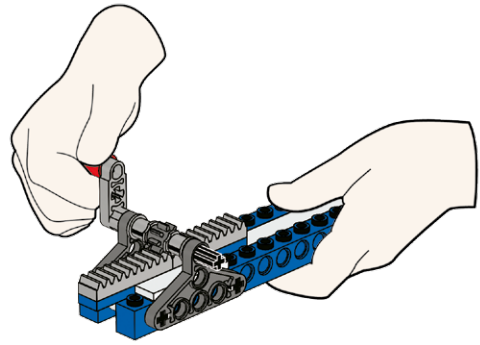

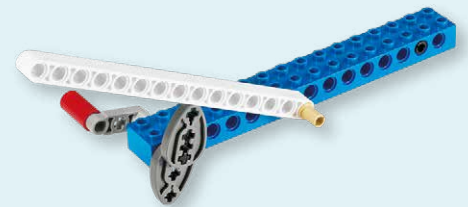
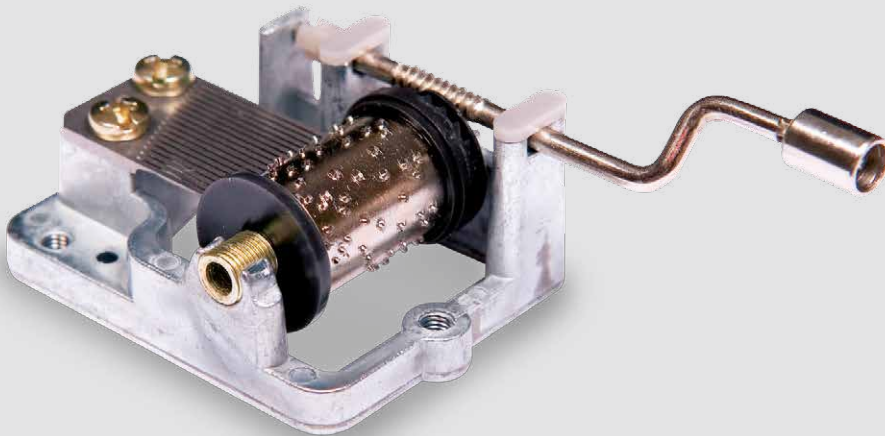
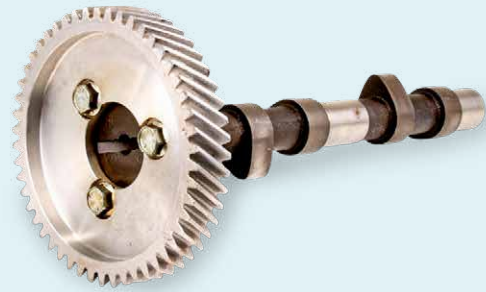

## Mechanisms: Cam

A cam is a shaped frame turning about an axis, like a rotating wheel.

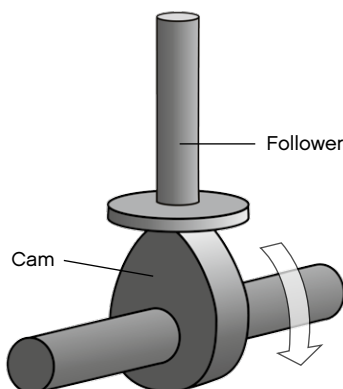

The profile of a cam allows it to control the timing and degree of movement of a follower. A cam can also be regarded as a continuous, variable inclined plane. Cams can be circular, pear shaped or irregular.

Cams and cam followers are very prone to wear due to friction. Cam followers often have tiny rollers attached to them to reduce this friction.

Common applications with cam mechanisms include clamps, an electric toothbrush and an engine camshaft.

### Did you know?

Spring-loaded cams are used by rock climbers to tightly grip rock crevices so that they can then attach climbing ropes.

# H1

**Build H1 book III, pages 26 to 27**

Turn the handle and describe the movement of the follower.

---

---

---

---

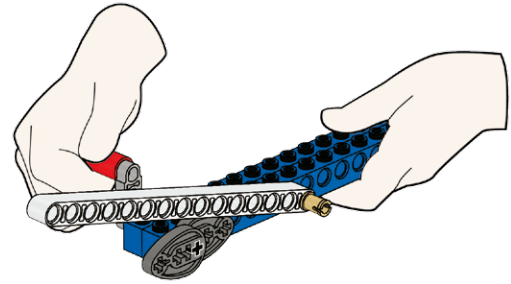

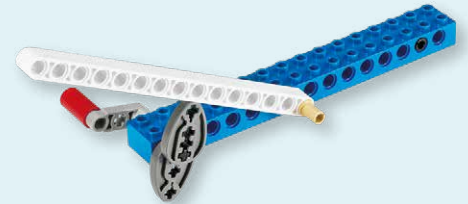
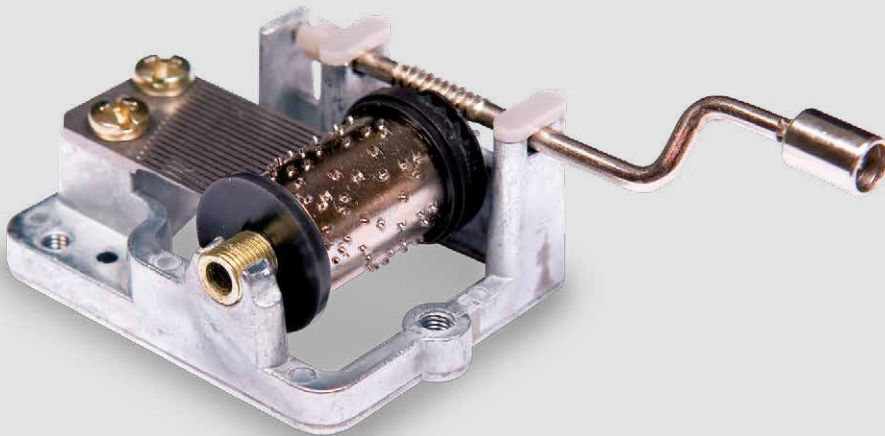

## Mechanisms: Cam

A cam is a shaped frame turning about an axis, like a rotating wheel.

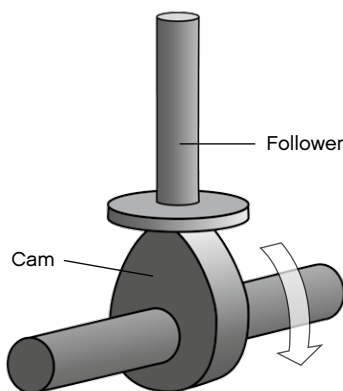

The profile of a cam allows it to control the timing and degree of movement of a follower. A cam can also be regarded as a continuous, variable inclined plane. Cams can be circular, pear shaped or irregular.

Cams and cam followers are very prone to wear due to friction. Cam followers often have tiny rollers attached to them to reduce this friction.

Common applications with cam mechanisms include clamps, an electric toothbrush and an engine camshaft.

### Did you know?

Spring-loaded cams are used by rock climbers to tightly grip rock crevices so that they can then attach climbing ropes.



**H1**

This model shows a double cam mechanism. As the two cams rotate, their shape and size dictates a sequence of upward and downward movements of the follower.

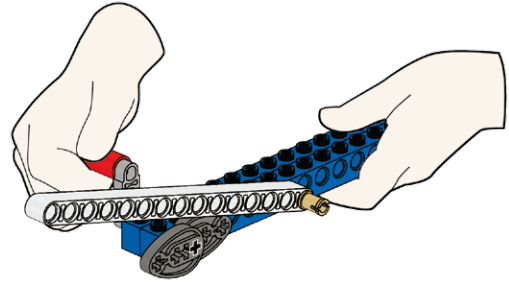

# Pawl and Ratchet

Student Worksheet

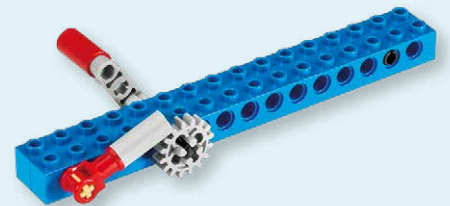

## Mechanisms: Pawl and Ratchet

A ratchet mechanism is based on a gear wheel and a pawl that follows as the wheel turns.

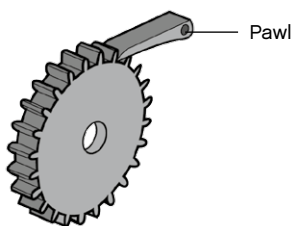

When the gear is moving in one direction, the pawl slides up and over the gear teeth, sending the pawl into the notch before the next tooth. The pawl is then jammed against the depression between the gear teeth, preventing any backwards motion.

Ratchet mechanisms are very useful devices for allowing linear or rotary motion in only one direction.

Common examples of ratchets are clocks, jacks and hoists.

### Did you know?

There are ratchets in some screw drivers that allow the user to turn with an effort in one direction and then turn back without turning the screw.

**I1**

**Build I1 book III, pages 28 to 29**

Turn the handle in both directions and describe what happens.

---

---

---

---

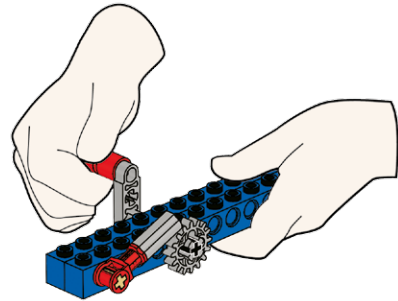

# Pawl and Ratchet

Teacher's Notes

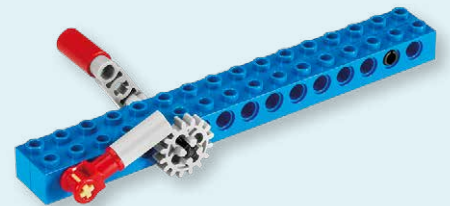
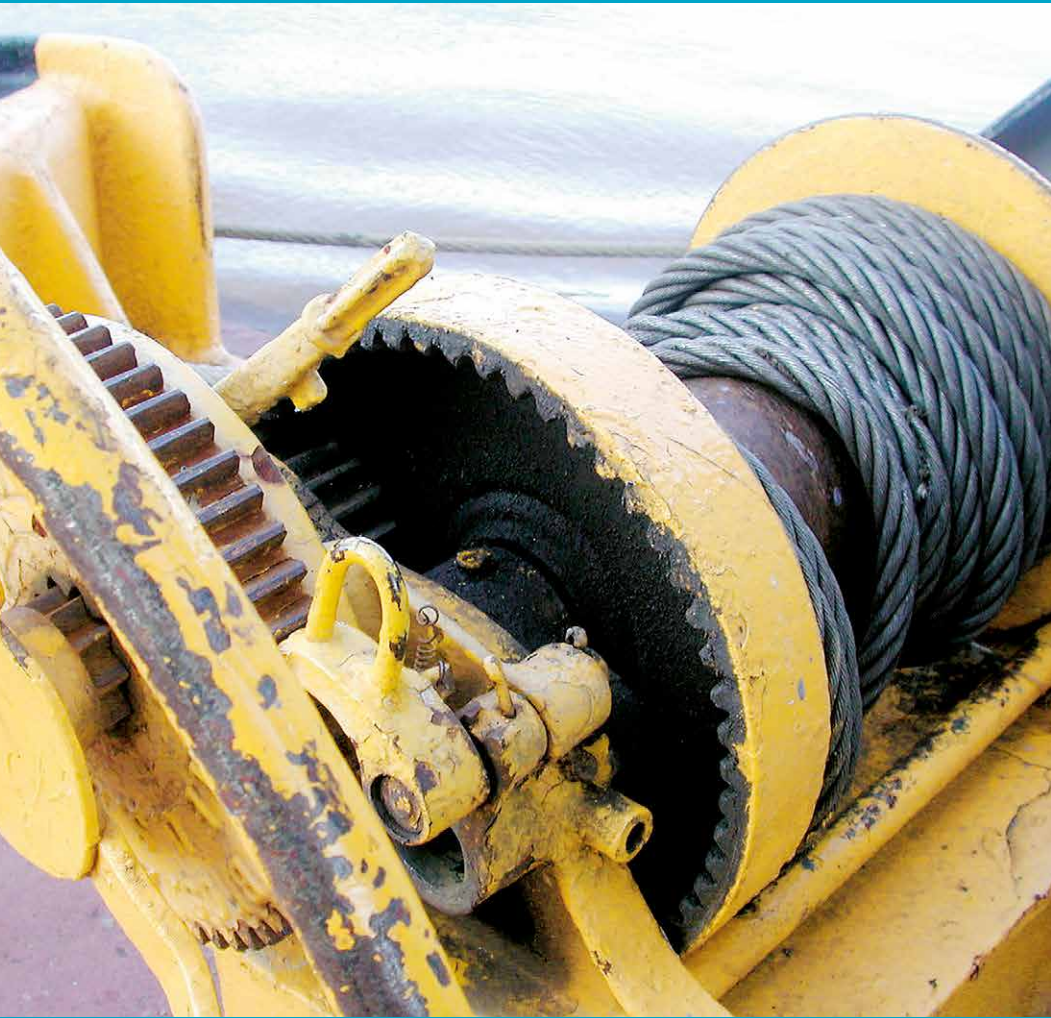

## Mechanisms: Pawl and Ratchet

A ratchet mechanism is based on a gear wheel and a pawl that follows as the wheel turns.

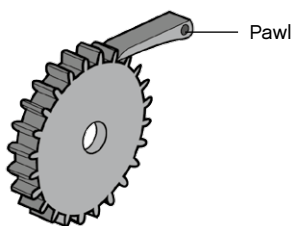

When the gear is moving in one direction, the pawl slides up and over the gear teeth, sending the pawl into the notch before the next tooth. The pawl is then jammed against the depression between the gear teeth, preventing any backwards motion.

Ratchet mechanisms are very useful devices for allowing linear or rotary motion in only one direction.

Common examples of ratchets are clocks, jacks and hoists.

### Did you know?

There are ratchets in some screw drivers that allow the user to turn with an effort in one direction and then turn back without turning the screw.

**I1**

This model shows a pawl and ratchet. When the handle is turned in one direction, the pawl slides up and over the gear teeth, sending the pawl into the depression before the next tooth. When the handle is turned in the other direction the pawl stops the movement.

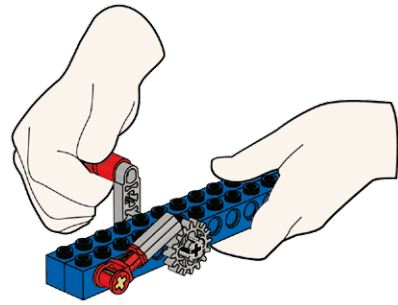

# Structures

Student Worksheet





# Structures

A structure is a construction in which individual parts are arranged to form a whole. All structures are under the influence of external and internal forces. Examples of external forces acting on a structure include the wind or the weight of trucks and buses passing over a bridge. An internal force could be the weight of a roof or the shaking of a large diesel engine on its mountings. Choice of materials will affect the safety level of a structure.

**Did you know?**  
In bridges, cranes, towers and even space stations, triangulation is often used to make structures rigid.

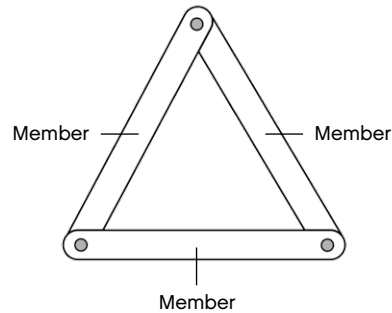

A frame structure is made from pieces called members. This frame is rigid because it is triangulated.

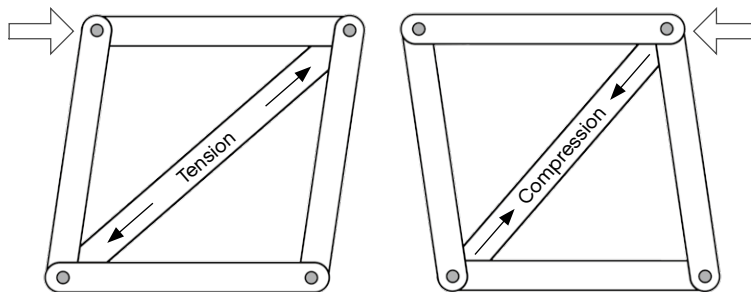

The forces that act on members are called tensile forces or compression forces. Tensile forces will stretch the structure and compression forces will squeeze the structure.

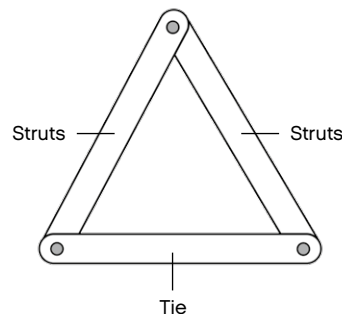

Members that are in tension are called ties; members that are under compression are called struts.

Common examples of structural principles can be found in scaffoldings, buildings and bridges.

**J1****Build J1 book III, page 30**

Push and pull to create tensile or compression forces on the members of the triangular frame. Explain what happens and why.

---



---



---

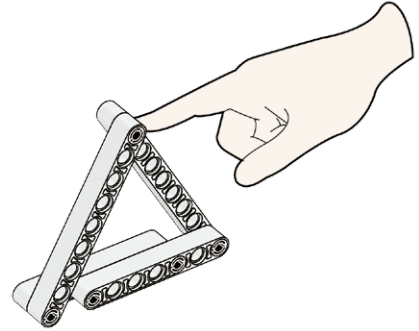

---

**J2****Build J2 book III, page 31**

Push and pull to create tensile or compression forces on the members of the rectangular frame. Explain what happens and why.

---



---



---

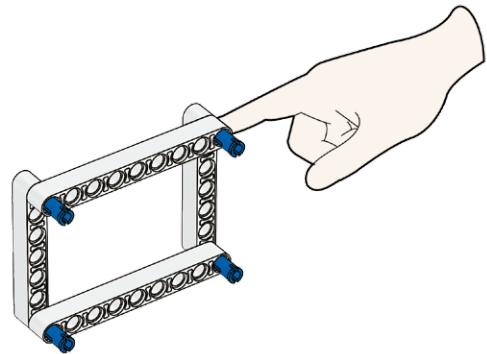

---

**J3****Build J3 book III, page 32**

Push and pull the rectangular frame to create tensile forces or compression forces. Explain what happens and why.

---



---



---



---

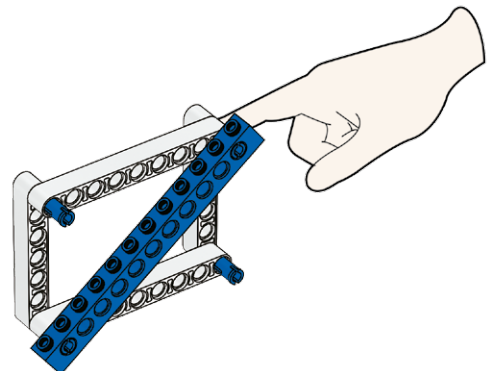

# Structures

Teacher's Notes

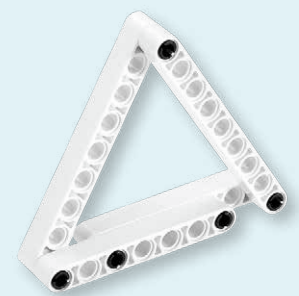

# Structures

A structure is a construction in which individual parts are arranged to form a whole. All structures are under the influence of external and internal forces. Examples of external forces acting on a structure include the wind or the weight of trucks and buses passing over a bridge. An internal force could be the weight of a roof or the shaking of a large diesel engine on its mountings. Choice of materials will affect the safety level of a structure.

**Did you know?**  
In bridges, cranes, towers and even space stations, triangulation is often used to make structures rigid.

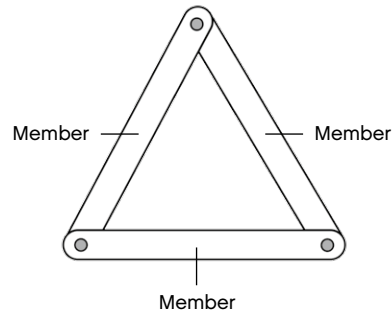

A frame structure is made from pieces called members. This frame is rigid because it is triangulated.

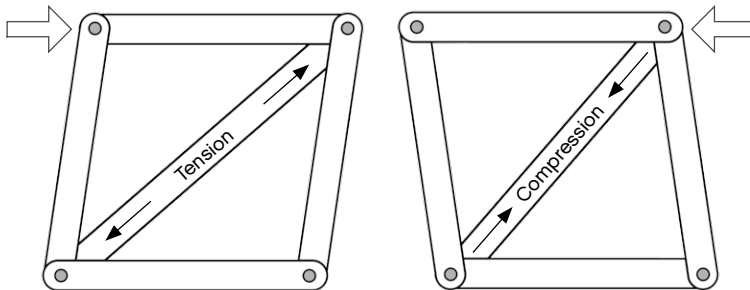

The forces that act on members are called tensile forces or compression forces. Tensile forces will stretch the structure and compression forces will squeeze the structure.

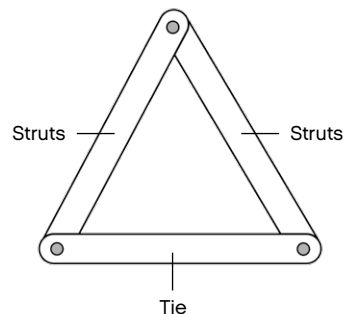

Members that are in tension are called ties; members that are under compression are called struts.

Common examples of structural principles can be found in scaffoldings, buildings and bridges.

**J1**

This model shows a triangular structure. When the triangular frame is pushed or pulled the shape doesn't change. The triangular frame is rigid.

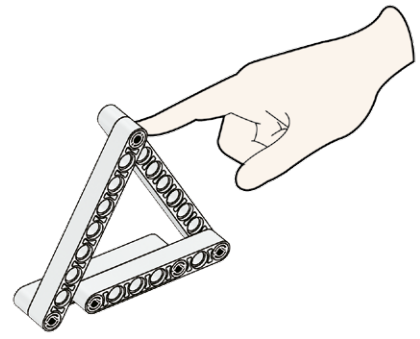
**J2**

This model shows a rectangular structure. The rectangular frame is easily changed when pushed and pulled. A rectangular frame is not rigid.

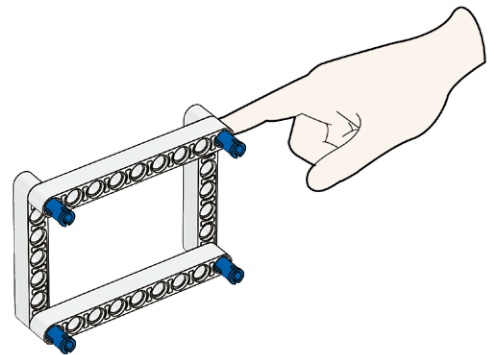
**J3**

This model shows a rectangular structure supported by a cross member. The rectangular frame is prevented from changing when pushed and pulled by the cross member. The cross member makes the rectangular frame rigid.

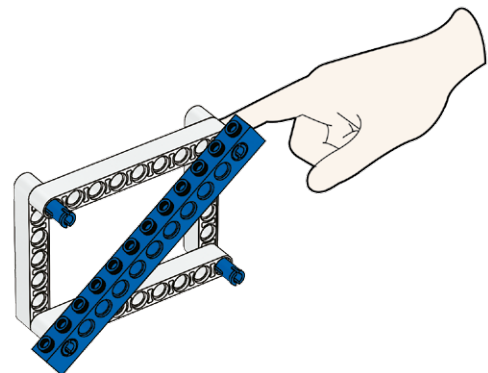



## Beam Balance

### Science

- Experiment and measure the effect of force on an object
- Forces
- Scientific investigation
- Simple machines – Lever

### Technology

- Assembling components
- Construct simple machines
- Evaluating
- Mechanical advantage
- Properties of materials

### Engineering

- Describe and explain parts of a structure and the effects of loads
- Test and evaluate before making improvements

### Mathematics

- Determine percent of error
- Develop, analyze, and explain methods for solving problems involving proportions, such as scaling and finding equivalent ratios
- Select and apply techniques to accurately find length measures to appropriate levels of precision
- Solve problems involving scale factors, using ratio and proportion

### Vocabulary

- Effort
- Equilibrium
- Fulcrum
- Levers
- Load
- Weight

### Other Materials Required

- Measuring tape
- Calibrated weighing machine

**Connect**

The simplest weighing machine is a beam balance. The original form of a balance consisted of a beam with a fulcrum at its center. A change of weight on either side of the balance will change the beam's positioning and affect the balance achieved.

**You will build a model beam balance and investigate how its function is influenced by changes in weight and position.**

## Construct

### Build the Beam Balance and Loads

(building instructions 15A and 15B to page 9, step 9)

- Make sure the arm moves up and down freely and the beam balance is in a state of equilibrium

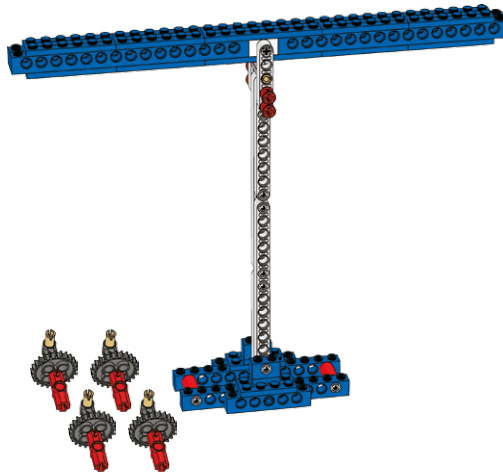



## Contemplate

### Why is it in a state of equilibrium?

Place the load and efforts as shown and use the formulas for levers to find the mechanical advantage and to explain what happens.

First, observe the mechanical advantage of beam balance A.  
*Record the mechanical advantage on the worksheet.*

Then use the formula for calculating the amount of effort needed to lift a given load to explain why the beam balance is in a state of equilibrium.  
*Record your findings on the worksheet.*

Next, follow the same procedure for beam balances B and C.

*Beam balance A (page 10, step 10) presents a mechanical advantage of 1. The beam balance is in a state of equilibrium because the weight on each side of the fulcrum is the same and the distance of the weight from the fulcrum on each side is the same.*

*Beam balance B (page 11, step 11) presents a mechanical advantage of 2. The beam balance is in a state of equilibrium, because the weight on the left of the fulcrum is half the weight on the right but it is twice as far from the fulcrum as the weight on the right.*

*Beam balance C (page 12, step 12) presents a mechanical advantage of 3. The beam balance is in a state of equilibrium because the weight on the left of the fulcrum is one third the weight on the right but it is three times as far from the fulcrum as the weight on the right.*

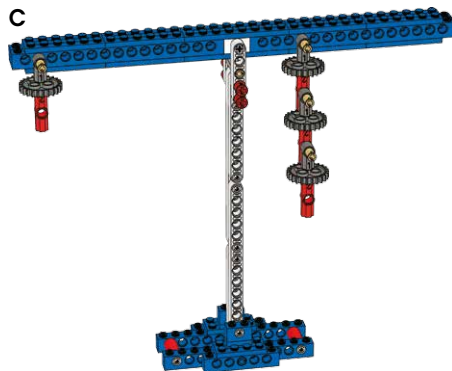
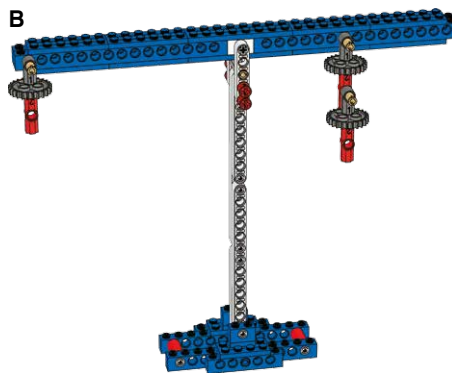
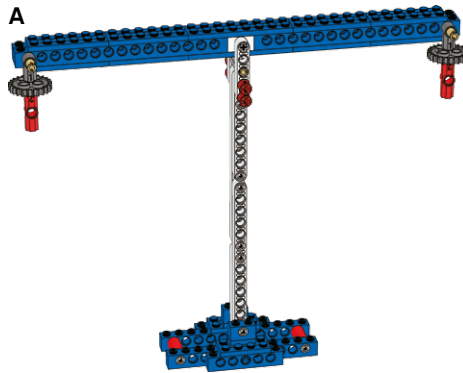

**Hint:**  
 You can find all of the formulas you need to perform this investigation in the principle models section for lever.

**Hint:**  
 Use this formula to help explain why each model is balanced:  
 $effort \times length\ of\ effort\ arm = load \times length\ of\ load\ arm.$

**Did you know?**



The loads weigh 2 g each.

## Continue

### How much does it weigh?

Your challenge is to use the balance to work out the weight of assembly A.

First, put assembly A on one arm and the preassembled weights on the other arm to find the position where the balance is in equilibrium.

Then use these positions to calculate the weight of assembly A.

Next, use the calibrated weighing machine to check your accuracy.

*Record and explain your findings on the worksheet.*

Build your own set of weights from LEGO® parts and test their accuracy.

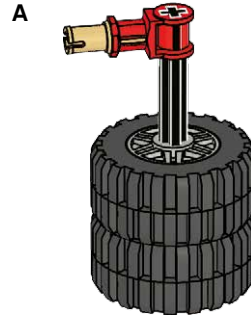

#### Hint:

Use this formula for calculating the amount of effort needed to lift a given load:  
 $\text{effort} \times \text{length of effort arm} = \text{load} \times \text{length of load arm}$ .

#### Hint:

Find out how accurate your calculation was by finding the difference between the actual and calculated weight. Then divide the difference with the actual weight and multiply it by 100.

# Beam Balance

Name(s): \_\_\_\_\_

Date and Subject: \_\_\_\_\_

## Build the Beam Balance and Loads

(building instructions 15A and 15B to page 9, step 9)

- Make sure the arm moves up and down freely and the beam balance is in a state of equilibrium

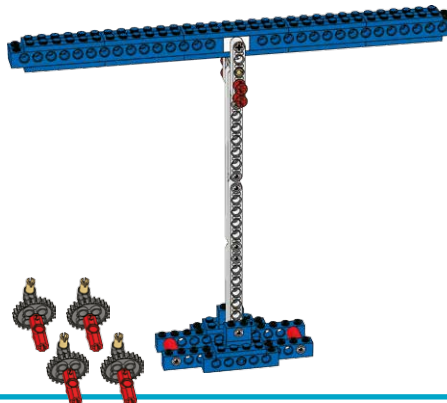

## Why is it in a state of equilibrium?

Place the load and efforts as shown and use the formulas for levers to find the mechanical advantage and to explain what happens.

First, observe the mechanical advantage of beam balance A.

Then use the formula for calculating the amount of effort needed to lift a given load to explain why the beam balance is in a state of equilibrium.

Next, follow the same procedure for beam balances B and C.

Use this formula to help explain why each model is balanced  $effort \times length\ of\ effort\ arm = load \times length\ of\ load\ arm$ .

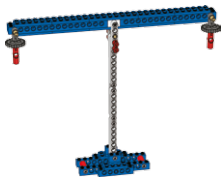
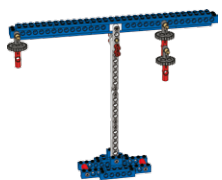
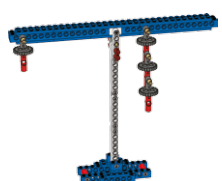
	Mechanical Advantage	Weight of Load	Load Distance from Fulcrum	Weight of Effort	Effort Distance from Fulcrum
<b>A</b>  (page 10, step 10)					
<b>B</b>  (page 11, step 11)					
<b>C</b>  (page 12, step 12)					

### How much does it weigh?

Your challenge is to use the balance to work out the weight of assembly A.

Put assembly A one arm and balance it with preassembled weights on the other arm. Use these positions to calculate the weight of assembly A.

Use the calibrated weighing machine to check your accuracy.

Build your own set of weights from LEGO® parts and test their accuracy.

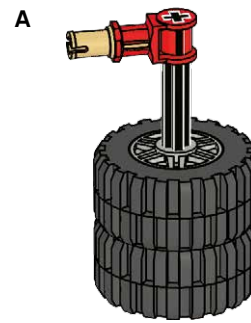

	Calculated Weight of Load	Measured Weight of Load	Percentage of Accuracy
A 			

**Hint:**

Find out how accurate your calculation was by finding the difference between the actual and calculated weight. Then divide the difference with the actual weight and multiply it by 100.

**Explain your findings:**

---



---



---







---

# Beam Balance

Name(s): \_\_\_\_\_

Date: \_\_\_\_\_

NGSS GOALS	 <b>BRONZE</b>	 <b>SILVER</b>	 <b>GOLD</b>	 <b>PLATINUM</b>
<p><b>1. Student work related to this Crosscutting Concept:</b>                      In this project, we completed the measurements and calculations to show the proportional relationship between mechanical advantage, load weight and load distance.</p>				
<p><b>Scale, Proportion, and Quantity:</b></p> <p>Use proportional relationships to gather information about the magnitude of properties.</p>	<ul style="list-style-type: none"> <li>We built the beam balance.</li> <li>We completed the predictions and measurements for beam balance A.</li> </ul> <input type="checkbox"/>	<ul style="list-style-type: none"> <li>We met Bronze.</li> <li>We completed the predictions and measurements for beam balance B.</li> </ul> <input type="checkbox"/>	<ul style="list-style-type: none"> <li>We met Silver.</li> <li>We completed the predictions and measurements for beam balance C.</li> </ul> <input type="checkbox"/>	<ul style="list-style-type: none"> <li>We met Gold.</li> <li>We used our work on the beam balance activity to plan a solution to the 'How much does it weigh?' challenge.</li> </ul> <input type="checkbox"/>
<p><b>2. Student work related to this Practice:</b>                      In this project, we tested our beam balance under different loads and completed calculations such as mechanical advantage and <math>\text{effort} \times \text{length of effort arm} = \text{load} \times \text{length of load arm}</math>. We completed the 'How much does it weigh?' challenge.</p>				
<p><b>Using Mathematics and Computational Thinking:</b></p> <p>Apply mathematical concepts such as ratio, rate, percent, basic operations and simple algebra to scientific and engineering problems.</p>	<ul style="list-style-type: none"> <li>We wrote down the mechanical advantage for the beam balances as a ratio.</li> </ul> <input type="checkbox"/>	<ul style="list-style-type: none"> <li>We met Bronze.</li> <li>We used the formula: <math>\text{effort} \times \text{length of effort arm} = \text{load} \times \text{length of load arm}</math> for all three beam balance set-ups.</li> </ul> <input type="checkbox"/>	<ul style="list-style-type: none"> <li>We met Silver.</li> <li>We calculated a prediction for the weight of assembly A.</li> <li>We calculated our percentage of accuracy.</li> </ul> <input type="checkbox"/>	<ul style="list-style-type: none"> <li>We met Gold.</li> <li>We built two additional sets of weights to measure using our beam balance.</li> <li>We calculated a prediction for their weights.</li> <li>We calculated our percentage of accuracy.</li> </ul> <input type="checkbox"/>
<p><b>3. Student work related to this Practice:</b>                      In this project, we used our beam balance to measure the weight of different LEGO® part assemblies. We explained what we discovered.</p>				
<p><b>Constructing Explanations:</b></p> <p>Construct an explanation that includes quantitative relationships between variables that predicts phenomena.</p>	<ul style="list-style-type: none"> <li>We explained what we discovered.</li> <li>Our explanation included at least one example calculation.</li> </ul> <input type="checkbox"/>	<ul style="list-style-type: none"> <li>We met Bronze.</li> <li>Our explanation used more than two example calculations.</li> </ul> <input type="checkbox"/>	<ul style="list-style-type: none"> <li>We met Silver.</li> <li>Our explanation outlined how we used equations to predict the weights of LEGO Assemblies.</li> </ul> <input type="checkbox"/>	<ul style="list-style-type: none"> <li>We met Gold.</li> <li>Our explanation included our percentage of accuracy results.</li> <li>We described ideas for improving the accuracy of our beam balance.</li> </ul> <input type="checkbox"/>
<p>Notes:</p>				

## Tower Crane

### Science

- Experiment and measure the effect of force on an object
- Forces and structures
- Scientific investigation
- Simple machines – Pulleys

### Technology

- Assembling components
- Construct simple machines
- Controlling mechanisms – motors
- Evaluating
- Mechanical advantage

### Engineering

- Describe and explain parts of a structure and the effects of loads
- Engineering design
- Test and evaluate before making improvements

### Mathematics

- Determine percent of error
- Select and apply techniques and tools to accurately measure length with appropriate levels of precision
- Understand the metric system of measurement

### Vocabulary

- Fixed pulley
- Friction
- Load
- Mechanical advantage
- Movable pulley
- Pulley block and tackle
- Pulley system
- Slip

### Other Materials Required

- Measuring tape
- Stopwatch
- Weighing scales

**Connect**

Cranes are widely used to lift heavy objects and move them to different positions and heights. They are used on docks for loading and unloading ships. They are used in the construction industry for moving building materials. They are used in factories for moving goods and machinery. There are several different types of crane. Some are fixed to the ground, others can move around.

**You will build a model tower crane and investigate how its function is influenced by changes to the pulley system.**

## Construct

### Build the tower crane and Load

(building instructions 16A and 16B to page 28, step 38)

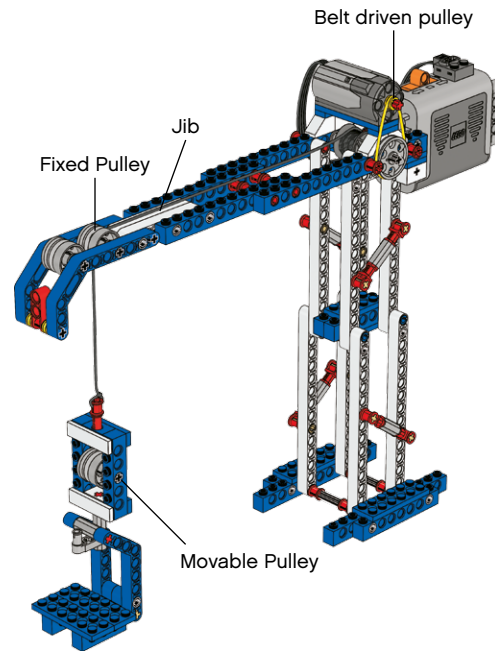

- Place the Tower Crane on the lid on top of the blue LEGO® storage box

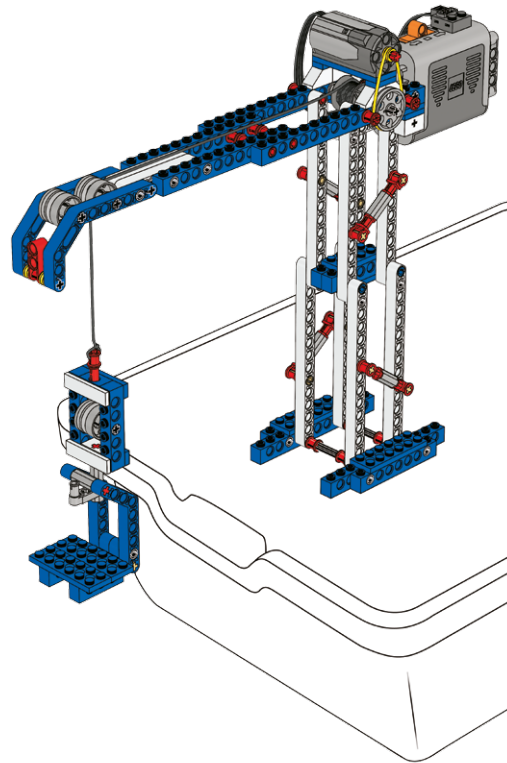

- Turn on the motor by pushing the battery box switch forward and let the string unwind and then let the motor wind it back up again
- Make sure all pulley wheels turn freely



## Contemplate

### Why do cranes use pulleys?

Cranes use pulley systems because they can pull with less effort than is needed in a direct lift.

First, observe the mechanical advantage and predict with which speed pulley setup A will lift the load.

*Record the mechanical advantage and your predictions on the worksheet.*

Then test your prediction.

*Record your findings on the worksheet.*

Next, follow the same procedure for pulley setups B and C.

*Pulley setup A (page 28, step 38) presents a mechanical advantage of 1. It functions with a speed of approximately 0.1 m/sec.*

*Pulley setup B (page 29, step 39) presents a mechanical advantage of 2. It functions with a speed of approximately 0.05 m/sec.*

*Pulley setup C (page 30, step 40) presents a mechanical advantage of 3. It functions with a speed of approximately 0.03 m/sec.*

### Explaining the test results.

*Pulley setup A is fast but presents no advantage in terms of needed force.*

*Pulley setup B is slower but has a mechanical advantage of 2, meaning that it only requires half the effort to lift the load. This also means that it will be able to lift twice the load using the same effort.*

*Pulley setup C is slower than both pulley setup A and B, but has a mechanical advantage of 3, meaning that it only requires one third of the effort pulley setup A needed to lift the load. This also means that it will be able to lift three times the load using the same effort.*

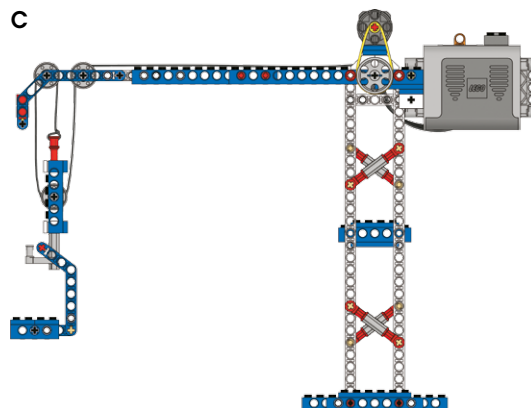
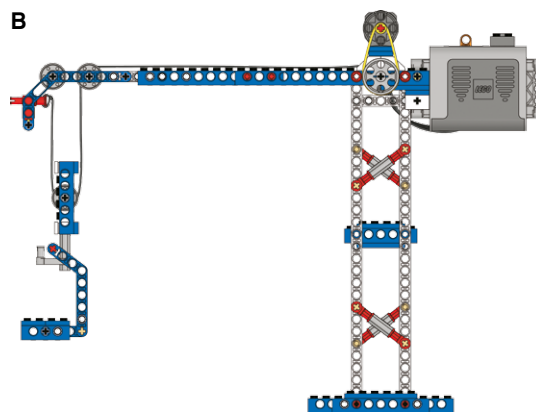
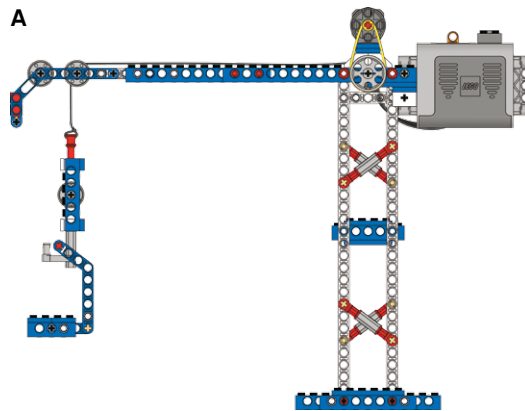

**Hint:**  
To accurately measure force, use a force meter.

**Hint:**  
The LEGO® string is 2 meters (≈ 2 yd) long.

**Hint:**  
You can find all of the formulas you need to perform this investigation in the principle models section for pulley.

## Continue

### Redesign needed?

Tower cranes are often built to match specific needs.

Now redesign the tower crane to make it the best in its class. We have highlighted some questions you could explore. Choose one area that you would like to investigate.

Then design a test that will help you explore how it functions and possible additional improvements you could make to your new tower crane. Remember to record all your test results.

### When the students have chosen an area of interest sparked by the 'what if' suggestions ask them to:

- Explain clearly the relevant part in the original model
- Identify the key features of that part that makes it work in the way that it does
- Consider which of these key features might be changed
- Make possible changes to see their effect
- Decide which changes achieve the desired effect
- Record their new design and add notes to explain
  - What changes they made
  - Why they made them
  - The effect that the changes have had

Students can record their designs by sketching them, or by taking digital photos or video. It will help if students work collaboratively as they will be able to question one another as they move through the task.

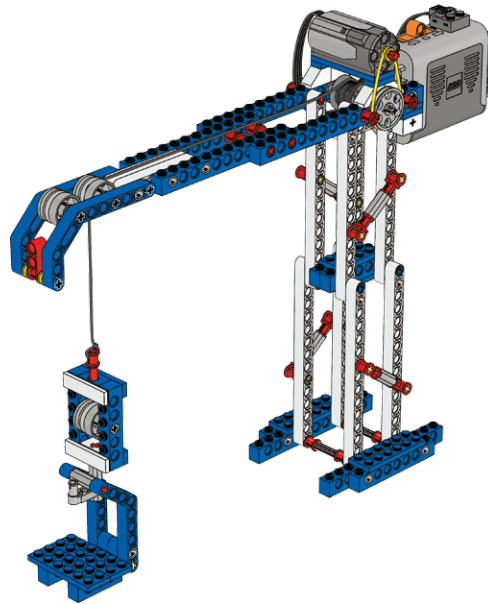

# Tower Crane

Name(s): \_\_\_\_\_

Date and Subject: \_\_\_\_\_

## Build the Tower Crane and Load

(building instructions 16A and 16B to page 28, step 38)

- Place the tower crane on the lid of the blue LEGO® storage box
- Turn on the motor by pushing the battery box switch forward and let the string unwind and then let the motor wind it back up again
- Make sure all pulley wheels turn freely

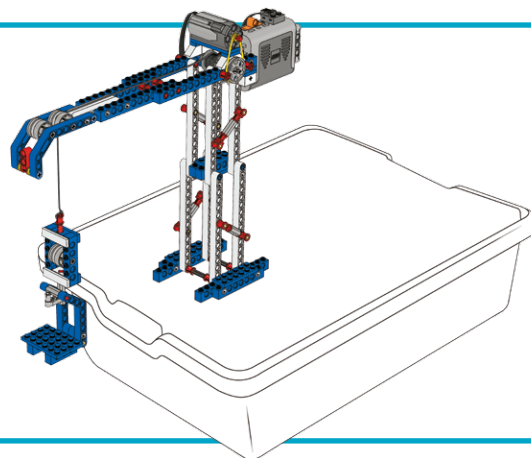

## Why do cranes use pulleys?

Cranes use pulley systems because they can pull with less effort than is needed in a direct lift.

First, observe the mechanical advantage and predict with which speed pulley setup A will lift the load.

Then test your prediction. Next, follow the same procedure for pulley setups B and C.

Test several times to make sure your results are consistent.

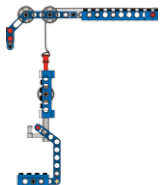
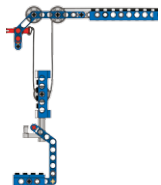
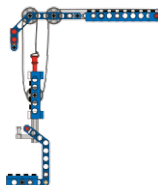
	Mechanical Advantage	My Prediction	Length Lifted	Lifting Time	Speed
<b>A</b>  (page 28, step 38)					
<b>B</b>  (page 29, step 39)					
<b>C</b>  (page 30, step 40)					

## Redesign needed?

Tower cranes are often built to match specific needs. Now redesign the tower crane to make it the best in its class. We have highlighted some questions you could explore. Choose one area that you would like to investigate.

Then design a test that will help you explore how it functions and possible additional improvements you could make to your new tower crane. Remember to record all of your test results.

*What if you wanted to pick up from one place and put down to the left or right of that place – how would you change the structure where the jib meets the tower?*

*What if you wanted to lift loads more quickly – how would you change the arrangement for raising the pulley?*

*What if you wanted to lift heavier loads – how would you change the pulley?*



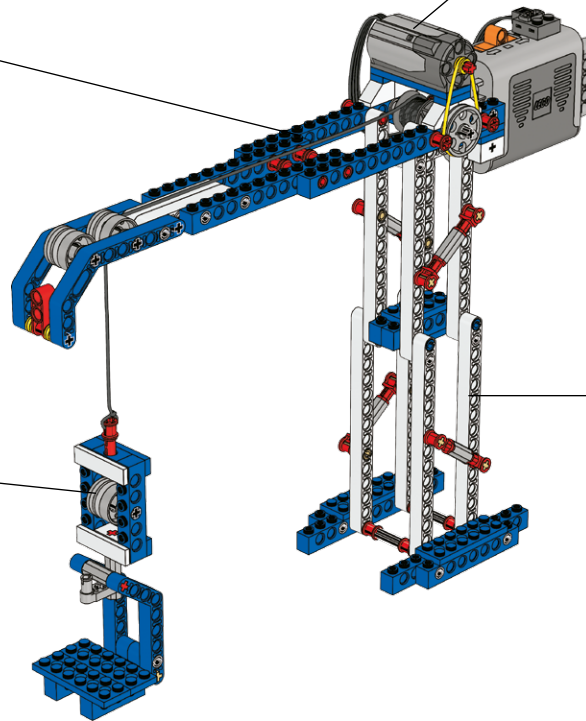

*What if you want the crane to lift loads higher – how would you change the tower?*



# Tower Crane

Name(s): \_\_\_\_\_

Date: \_\_\_\_\_

NGSS GOALS	 BRONZE	 SILVER	 GOLD	 PLATINUM
<b>1. Student work related to this Crosscutting Concept:</b> In this project, we explored the cause and effect relationship between the pulley arrangement in our tower crane and the weight and speed of the load we lift.				
<b>Cause and Effect:</b>  Students use cause and effect relationships to explain and predict behaviors in design systems.	<ul style="list-style-type: none"> <li>We observed our tower crane lift an object with pulley setup A.</li> <li>We predicted what would happen with pulley setup B.</li> </ul> <input type="checkbox"/>	<ul style="list-style-type: none"> <li>We met Bronze.</li> <li>We noted how pulley setup B caused a change in our lifting length and lifting time.</li> <li>We predicted what would happen with pulley setup C.</li> </ul> <input type="checkbox"/>	<ul style="list-style-type: none"> <li>We met Silver.</li> <li>We noted how pulley setup C caused a change in our lifting length and lifting time.</li> <li>We observed what was different about each pulley setup.</li> </ul> <input type="checkbox"/>	<ul style="list-style-type: none"> <li>We met Gold.</li> <li>We explained the functions and possible additional improvements of the new tower crane.</li> </ul> <input type="checkbox"/>
<b>2. Student work related to this Practice:</b> In this project, we built a working model of a tower crane to test different types of pulley systems.				
<b>Developing and Using Models:</b>  Develop and use a model to generate data to test ideas about phenomena in designed systems, including those representing inputs and outputs.	<ul style="list-style-type: none"> <li>We built the tower crane with pulley setup A.</li> <li>We completed our measurements and calculations for pulley setup A.</li> </ul> <input type="checkbox"/>	<ul style="list-style-type: none"> <li>We met Bronze.</li> <li>We built pulley setup B.</li> <li>We completed our measurements and calculations for pulley setup B.</li> <li>We completed our tests of A and B at least twice.</li> </ul> <input type="checkbox"/>	<ul style="list-style-type: none"> <li>We met Silver.</li> <li>We built pulley setup C.</li> <li>We completed our measurements and calculations for pulley setup C.</li> <li>We completed all of our tests at least three times.</li> </ul> <input type="checkbox"/>	<ul style="list-style-type: none"> <li>We met Gold.</li> <li>We made changes to the two pulleys found near the motor.</li> <li>We used our observations of this experiment to help us answer our redesign questions.</li> </ul> <input type="checkbox"/>
<b>3. Student work related to this Practice:</b> In this project, we redesigned our tower crane. We developed an investigation to explore how the new design functions.				
<b>Planning and Carrying Out Investigations:</b>  Collect data about the performance of a proposed object.	<ul style="list-style-type: none"> <li>We picked a redesign question.</li> <li>We created a data table to organize our measurements and observations.</li> </ul> <input type="checkbox"/>	<ul style="list-style-type: none"> <li>We met Bronze.</li> <li>We identified our independent and dependent variables.</li> <li>We completed at least two tests.</li> </ul> <input type="checkbox"/>	<ul style="list-style-type: none"> <li>We met Silver.</li> <li>We identified our experimental controls (what we kept constant for each experiment).</li> <li>We completed at least three tests.</li> <li>Our data helped us evaluate our redesign.</li> </ul> <input type="checkbox"/>	<ul style="list-style-type: none"> <li>We met Gold.</li> <li>We completed multiple trials for all of our tests.</li> <li>We created a new data table to clearly compare our redesign test results with the data from our first experiments.</li> </ul> <input type="checkbox"/>
Notes:				



## Ramp

### Science

- Experiment and measure the effect of force on an object
- Scientific investigation
- Simple Machines – Inclined Plane
- Simple Machines – Wheel and Axle

### Technology

- Assembling components
- Construct simple machines
- Evaluating
- Mechanical advantage

### Engineering

- Describe and explain parts of a structure and the effects of loads
- Engineering design
- Test and evaluate before making improvements

### Mathematics

- Determine percent of error
- Select and apply techniques and tools to accurately find length and angle measures to appropriate levels of precision
- Understand the metric system of measurement

### Vocabulary

- Angle
- Efficiency
- Effort
- Friction
- Load
- Inclined Plane
- Mechanical advantage

### Other Materials Required

- 30 cm (≈ 11.8 in) plank of wood or thick piece of cardboard
- 60 cm (≈ 23.6 in) plank of wood or thick piece of cardboard
- Fabrics and abrasive papers to create different surfaces
- Measuring tape
- Weighing scales
- Pile of books or boxes to elevate the planks

## Connect



Ramps have been used since ancient times to help move heavy objects or large quantities of materials from one level to another. Today, automobile transport services use ramp on their trucks to load multiple vehicles on one transport. These multi-vehicle transports use ramps for easy of use, safety and efficiency.

**You will build a model ramp and the box frame and investigate how angle and wheels affects the needed effort.**

## Construct

**Build the Box Frame, Roller and Effort Weight**  
(building instructions 17A and 17B to page 11, step 15)

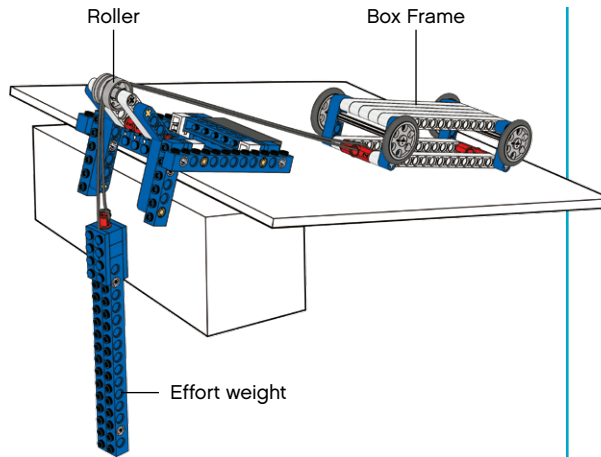

- Make sure the wheels on the box frame turn freely
- The box frame can be turned upside down, to be used as a sled, without the wheels. Or turned around again as a cart with wheels.

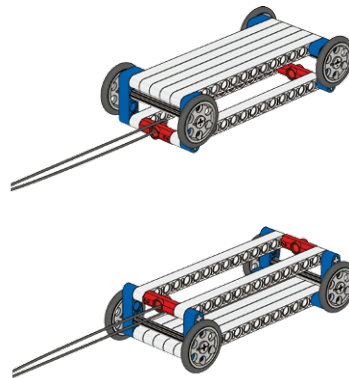

## Build the Ramp

- Place a support so the top of the 30 cm ( $\approx 11.8$  in) plank is situated 10 cm ( $\approx 3.9$  in) off the floor
- Place the box frame on the ramp and the roller at the top edge. Let the effort weight hang loose over the edge
- Have the 60 cm ( $\approx 23.6$  in) plank ready to make changes to the ramp

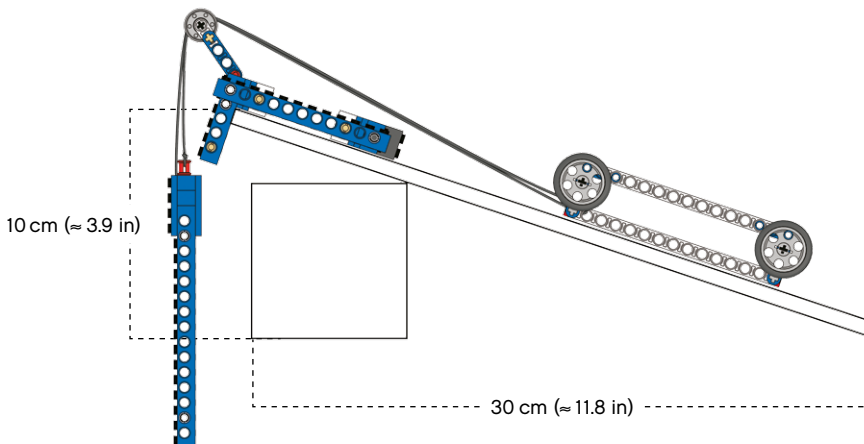



## Contemplate

### What is the advantage of using the ramp?

Investigate the difference between ideal and actual mechanical advantage.

First, calculate the ideal mechanical advantage and predict how much effort is actually needed to pull the box frame A to the top of the ramp. Record the mechanical advantage and your predictions on the worksheet.

Then test how much effort is needed by adding LEGO® bricks to the effort weight and calculate the actual mechanical advantage. Record your findings on the worksheet.

Next, follow the same procedure for box frames B, C and D.

*The ideal mechanical advantage of the short ramp is 3. The actual mechanical advantage depends on the surface of the plank.*

*The ideal mechanical advantage of the long ramp is 6. The actual mechanical advantage depends on the surface of the plank.*

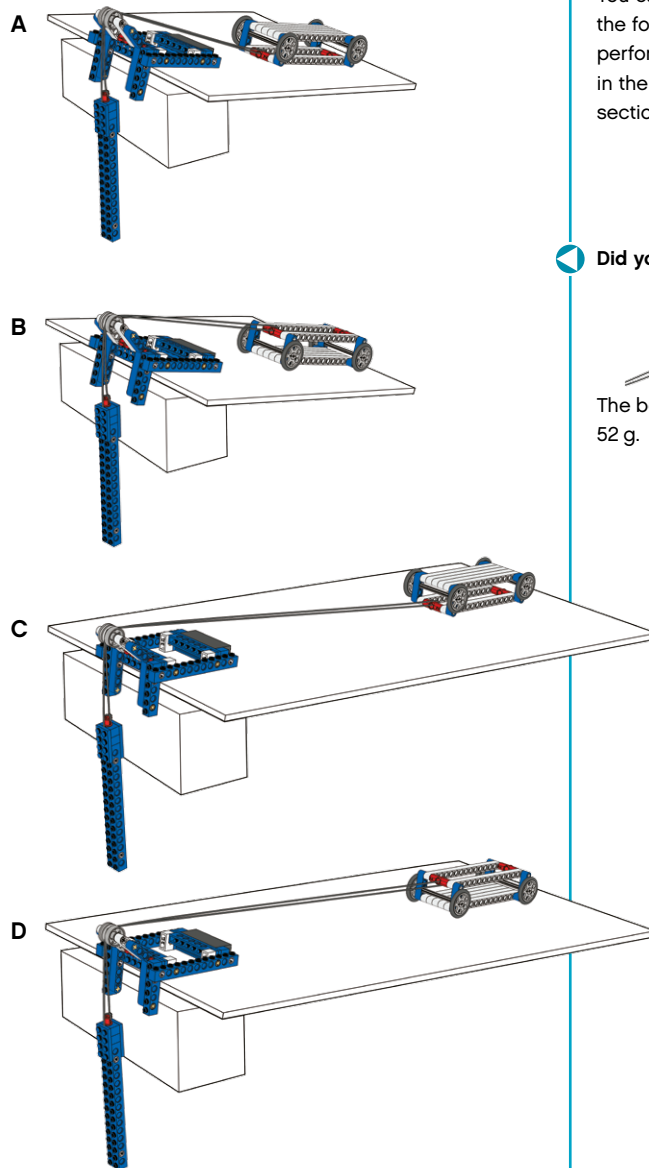

### Hint:

You can find all of the formulas you need to perform this investigation in the principle models section for inclined plane.

### Did you know?

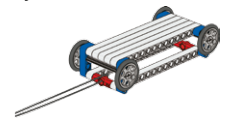

The box frame weighs 52 g.

## Continue

### Redesign needed?

A ramp can come in many shapes and sizes to match specific needs.

Now redesign the ramp to make it the best in its class. We have highlighted some questions you could explore. Choose one area that you would like to investigate.

Then design a test that will help you explore how it functions and possible additional improvements you could make to your new ramp. Remember to record all your test results.

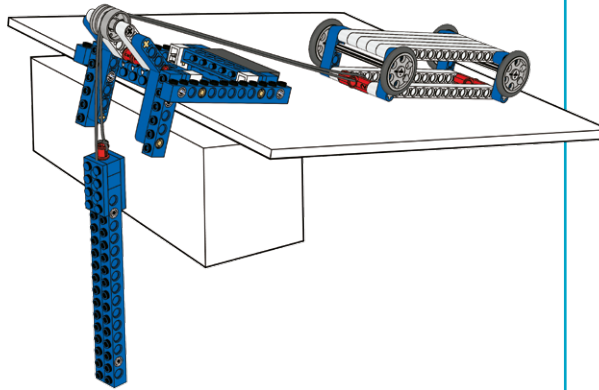

**When the students have chosen an area of interest sparked by the 'what if' suggestions ask them to:**

- a) Explain clearly the relevant part in the original model
- b) Identify the key features of that part that makes it work in the way that it does
- c) Consider which of these key features might be changed
- d) Make possible changes to see their effect
- e) Decide which changes achieve the desired effect
- f) Record their new design and add notes to explain
  - a. What changes they made
  - b. Why they made them
  - c. The effect that the changes have had

Students can record their designs by sketching them, or by taking digital photos or video. It will help if students work collaboratively as they will be able to question one another as they move through the task.

# Ramp

Name(s): \_\_\_\_\_

Date and Subject: \_\_\_\_\_

## Build the Box Frame, Roller and Effort Weight

(building instructions 17A and 17B to page 11, step 15)

- Make sure the wheels on the box frame turns freely
- The box frame can be turned upside down, to be used as a sled, without the wheels. Or turned around again as a cart with wheels

## Build the Ramp

- Place a support so the top of the 30 cm ( $\approx$  11.8 in) plank is situated 10 cm ( $\approx$  3.9 in) off the floor
- Place the box frame on the ramp and the roller at the top edge. Let the effort weight hang loose over the edge
- Have the 60 cm ( $\approx$  23.6 in) plank ready to make changes to the ramp

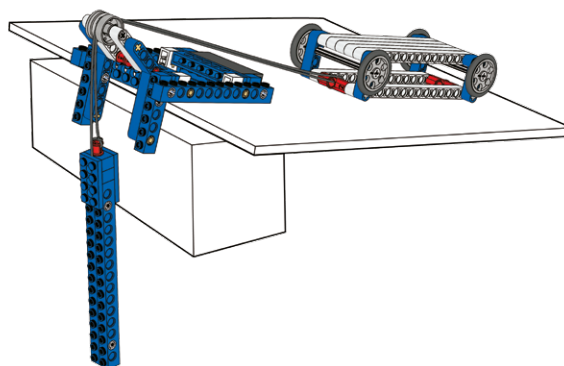

## What is the advantage of using the ramp?



Investigate the difference between ideal and actual mechanical advantage.

First, calculate the ideal mechanical advantage and predict how much effort is actually needed to pull box frame A to the top of the ramp.

Then test how much effort is needed by adding LEGO® bricks to the effort weight and calculate the actual mechanical advantage.

Calculate the percentage of accuracy between the ideal mechanical advantage and the actual mechanical advantage.

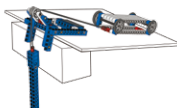
Next, follow the same procedure for box frames B, C and D.

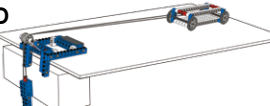
	Ideal Mechanical Advantage	My Prediction of Effort Needed	Actual Effort Needed	Actual Mechanical Advantage	Percentage of Accuracy
<b>A</b>  (page 11, step 15)					
<b>B</b>  (page 12, step 16)					
<b>C</b>  (page 11, step 15)					
<b>D</b>  (page 12, step 16)					

## Redesign needed?

A ramp can come in many shapes and sizes to match specific needs.

Now redesign the ramp to make it the best in its class. We have highlighted some questions you could explore. Choose one area that you would like to investigate.



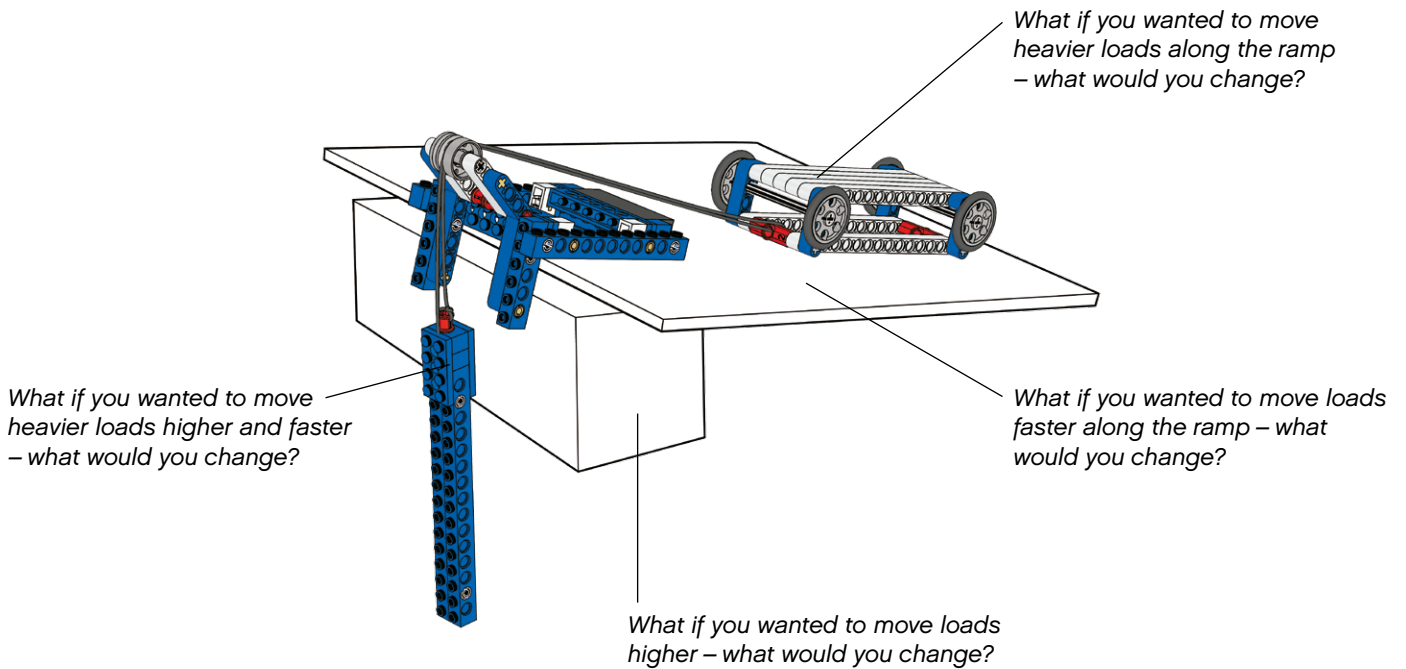

Then design a test that will help you explore how it functions and possible additional improvements you could make to your new ramp. Remember to record all of your test results.



# Ramp

Name(s): \_\_\_\_\_

Date: \_\_\_\_\_

NGSS GOALS	 <b>BRONZE</b>	 <b>SILVER</b>	 <b>GOLD</b>	 <b>PLATINUM</b>
<b>1. Student work related to this Crosscutting Concept:</b> In this project, we redesigned a structure in our ramp system to move heavier loads, move them faster, or move them higher.				
<b>Structure and Function:</b>  Design structures to serve particular functions.	<ul style="list-style-type: none"> <li>We chose our design goal —move heavier loads, move them faster, or move them higher.</li> <li>We identified which structure in our ramp system needed to be changed.</li> </ul> <input type="checkbox"/>	<ul style="list-style-type: none"> <li>We met Bronze.</li> <li>We changed the relevant ramp structure to make it function as desired.</li> <li>Our test data showed that we made a small improvement (&lt; 2x improvement).</li> </ul> <input type="checkbox"/>	<ul style="list-style-type: none"> <li>We met Silver.</li> <li>Our test data showed that we made a large improvement. (&gt; 2x improvement).</li> </ul> <input type="checkbox"/>	<ul style="list-style-type: none"> <li>We chose a second design goal</li> <li>We identified ramp structure to change.</li> <li>We completed the redesign and our test data showed that we made an improvement.</li> </ul> <input type="checkbox"/>
<b>2. Student work related to this Practice:</b> In this project, we asked questions and defined problems to help us decide how to redesign our ramp system.				
<b>Asking Questions and Defining Problems:</b>  Ask questions that clarify and/or refine an engineering problem.	<ul style="list-style-type: none"> <li>We asked questions that only partially related to improving our ramp system.</li> </ul> <input type="checkbox"/>	<ul style="list-style-type: none"> <li>We met Bronze.</li> <li>We asked questions that were relevant to the features of the ramp we wanted to improve.</li> <li>Our questions resulted in at least one redesign idea.</li> </ul> <input type="checkbox"/>	<ul style="list-style-type: none"> <li>We met Silver.</li> <li>Our questions helped us clarify a test procedure to evaluate our design idea.</li> </ul> <input type="checkbox"/>	<ul style="list-style-type: none"> <li>We met Gold.</li> <li>Our questions lead us to more than one redesign idea that we tested with an experiment.</li> </ul> <input type="checkbox"/>
<b>3. Student work related to this Practice:</b> In this project, we collected data during tests of the original ramp design. We analyzed and interpreted that data to help us begin our redesign project.				
<b>Analyzing and Interpreting Data:</b>  Analyze data to define whether a system best meets criteria for success.	<ul style="list-style-type: none"> <li>We compared ideal mechanical advantage for all four ramp experiments.</li> <li>We circled the best ideal mechanical advantage.</li> </ul> <input type="checkbox"/>	<ul style="list-style-type: none"> <li>We met Bronze.</li> <li>We compared actual mechanical advantage for all four ramp experiments.</li> <li>We circled the best actual mechanical advantage.</li> </ul> <input type="checkbox"/>	<ul style="list-style-type: none"> <li>We met Gold.</li> <li>We compared percentage of accuracy for all four ramp experiments.</li> <li>We circled the best percentage of accuracy.</li> </ul> <input type="checkbox"/>	<ul style="list-style-type: none"> <li>We used our data analysis to identify which ramp structure would affect the different goals we evaluated for our redesign —height, weight, and speed.</li> </ul> <input type="checkbox"/>
Notes:				



## Gear Racer

### Science

- Experiment and measure position versus time
- Motion
- Scientific investigation
- Mechanisms – Gear

### Technology

- Assembling components
- Evaluating
- Gear ratio

### Engineering

- Describe and explain parts of a gear box
- Engineering design
- Test and evaluate before making improvements

### Mathematics

- Determine percent of error
- Select and apply techniques and tools to accurately measure length to appropriate levels of precision
- Understand the metric system of measurement

### Vocabulary

- Acceleration
- Average speed
- Friction
- Gearing
- Gear ratio
- Surface
- Wheels

### Other Materials Required

- Measuring tape
- Stop and start line
- Stopwatch

## Connect



Racing cars are exciting because they travel so fast. The fastest racing cars, Formula 1 racing cars travel at speeds of over 225 mph. The driver has to drive around bends that change direction. To do this the driver has to slow the car down without losing power. The driver uses a gearbox to do this. All cars have gearboxes and the development of gearboxes in racing cars has led to better gearboxes being available in family cars. In the same way the different materials and structures developed to make racing cars faster, stronger and lighter are now used to improve the performance of everyday cars.

**You will build a model gear racer and investigate how its speed can be influenced by shifting gears.**

**Construct**

**Build the Gear Racer**

(building instructions 18A and 18B to page 17, step 20)

- Keep the power lead clear of all moving parts

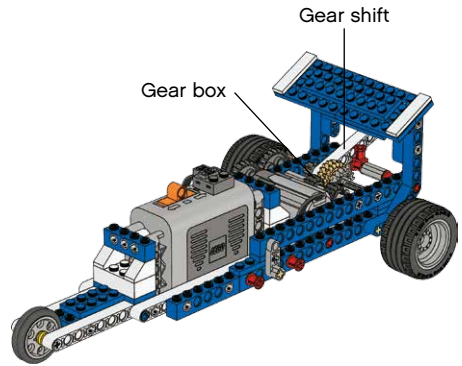

- Try the two gear positions and make sure the gears mesh

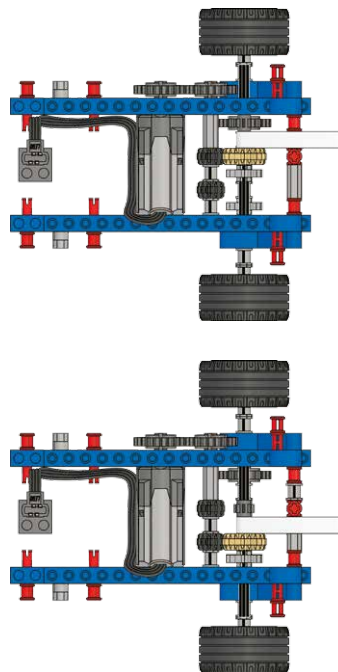

**Mark a Test Track**

- Mark a start line and finish line 2 m (≈ 2 yd) apart

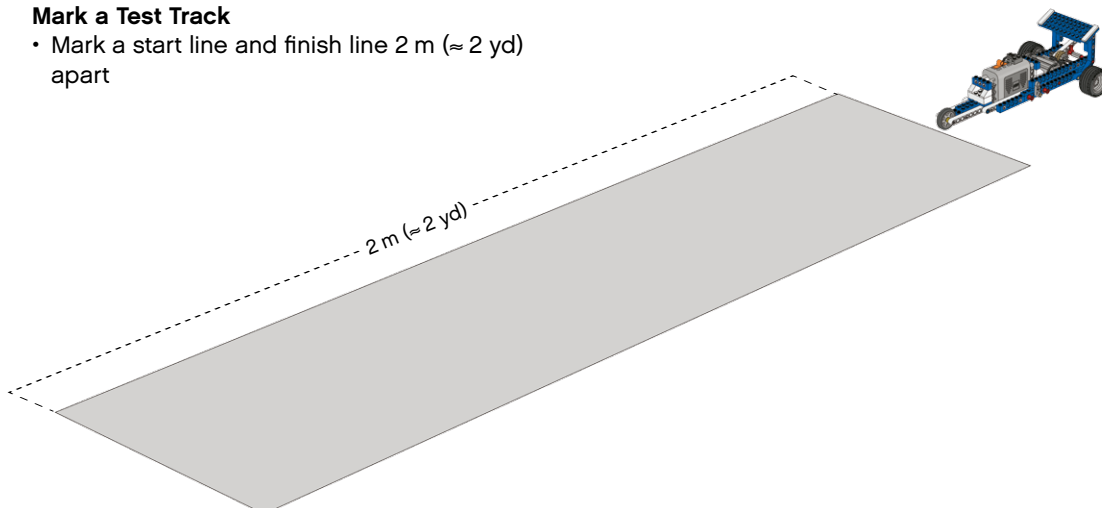



## Contemplate

### Why does a gear racer use a gear box?

Due to the gears in a gear racer it can deliver the best in both power and speed transmission.

Calculate the average speed of the gear racer by using this formula:

$$\text{Average speed} = \frac{\text{Distance}}{\text{Time}}$$

First, calculate the gear ratio of the gear racer with the gear set in position A and predict how much time the gear racer will need to do the 2 m ( $\approx$  2 yd) stretch.

*Record the gear ratio and your prediction on the worksheet.*

Then test your prediction and calculate the average speed.

*Record your findings on the worksheet.*

Next, follow the same procedure for the gear racer with the gear set in position B.

*The gear racer set in gear setting A (page 17, step 20) it has a 5:1 gear ratio*

$$\text{Gear ratio} = \frac{24}{24} \times \frac{20}{12} \times \frac{24}{8} = \frac{5}{1}$$

*and will do the 2 m ( $\approx$  2 yd) in 10 sec. resulting in an average speed of 0.2 m/sec.*

*The gear racer set in gear setting B (page 18, step 21) it has a 5:3 gear ratio*

$$\text{Gear ratio} = \frac{24}{24} \times \frac{20}{12} \times \frac{16}{16} = \frac{5}{3}$$

*and will do the 2 m ( $\approx$  2 yd) in 4 sec. resulting in an average speed of 0.5 m/sec.*

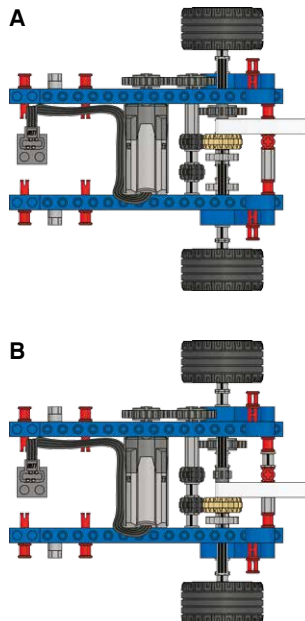

### Hint:

You can find all of the formulas you need to calculate gear ratio in the principle models section for gear.

### Hint:

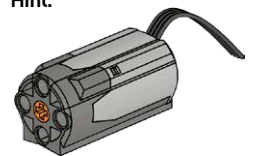

The LEGO® motor turns at about 400 rpm unloaded.



The circumference of the large LEGO wheel is 135.7 mm ( $\approx$  5.3 in).

## Continue

### Redesign needed?

Race cars come in many different types to fit the race type and race track.

Now redesign the gear racer to make it the best in its class. We have highlighted some questions you could explore. Choose one area that you would like to investigate.

Then design a test that will help you explore how it functions and possible additional improvements you could make to your new gear racer. Remember to record all of your test results.

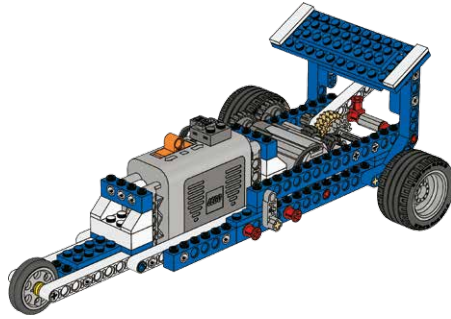

### When the students have chosen an area of interest sparked by the 'what if' suggestions ask them to:

- a) Explain clearly the relevant part in the original model
- b) Identify the key features of that part that makes it work in the way that it does
- c) Consider which of these key features might be changed
- d) Make possible changes to see their effect
- e) Decide which changes achieve the desired effect
- f) Record their new design and add notes to explain
  - a. What changes they made
  - b. Why they made them
  - c. The effect that the changes have had

Students can record their designs by sketching them, or by taking digital photos or video. It will help if students work collaboratively as they will be able to question one another as they move through the task.

# Gear Racer

Name(s): \_\_\_\_\_

Date and Subject: \_\_\_\_\_

## Build the Gear Racer

(building instructions 18A and 18B to page 17, step 20)

- Keep the power lead clear of all moving parts
- Try the two gear position and make sure the gears mesh

### Mark a Test Track

- Mark a start line and finish line 2 m (≈ 2 yd) apart

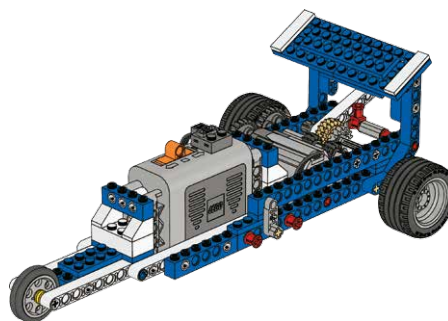

## Why does a gear racer use a gear box?

Due to the gears in a gear racer it can deliver the best in both power and speed transmission. Calculate the average speed of the gear racer by using this formula:

$$\text{Average speed} = \frac{\text{Distance}}{\text{Time}}$$

First, calculate the gear ratio of the gear racer with the gear set in position A and predict how much time the gear racer will need to do the 2 m (≈ 2 yd) stretch.

Then test your prediction and calculate the average speed.

Next, follow the same procedure for the gear racer with the gear set in position B.

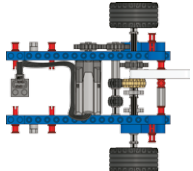
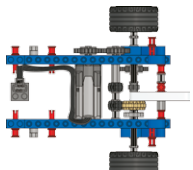
Gear Racer Gear Box Setting	Gear Ratio	Predicted Time	Actual Time	Percentage of Accuracy	Average Speed
<p><b>A</b></p>  <p>(page 17, step 20)</p>					
<p><b>B</b></p>  <p>(page 18, step 21)</p>					

## Redesign needed?

Race cars come in many different types to fit the race type and race track.

Now redesign the gear racer to make it best in its class. We have highlighted some questions you could explore. Choose one area that you would like to investigate.



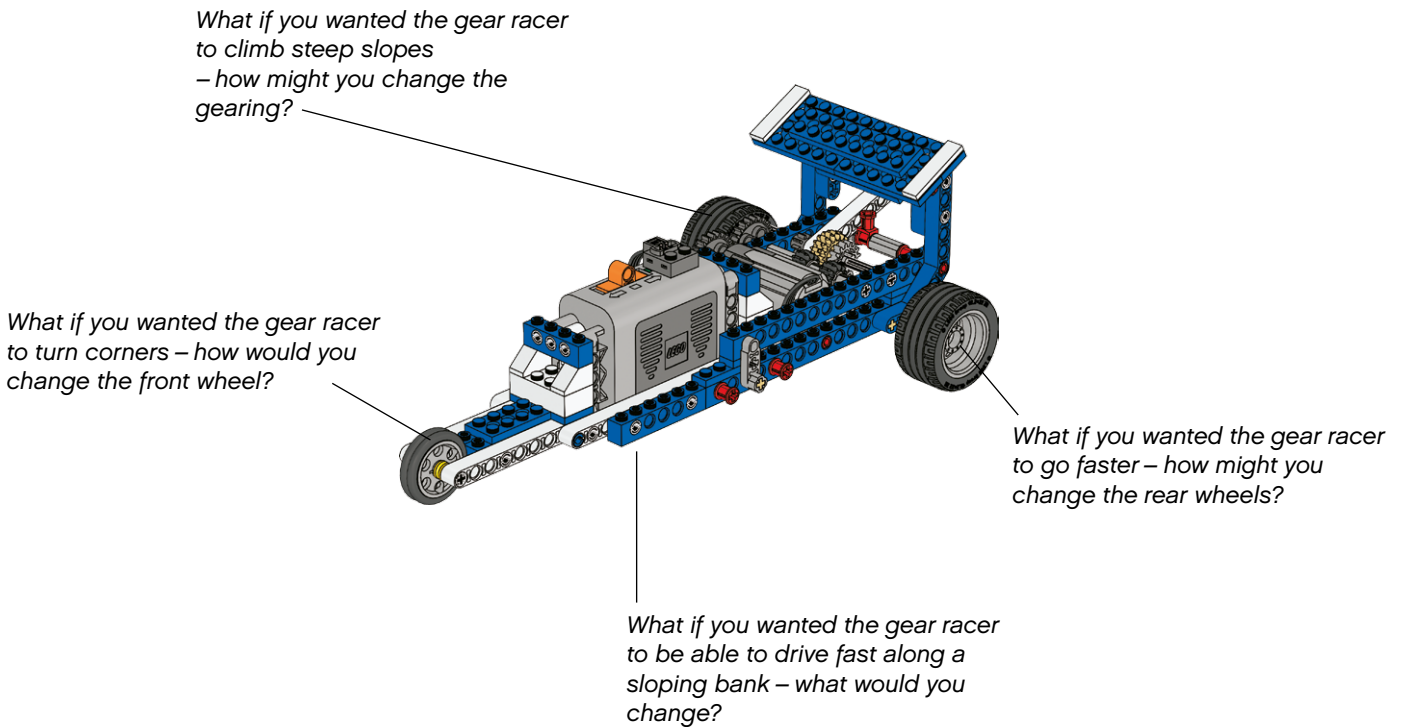

Then design a test that will help you explore how it functions and possible additional improvements you could make to your new gear racer. Remember to record all of your test results.



# Gear Racer

Name(s): \_\_\_\_\_

Date: \_\_\_\_\_

NGSS GOALS	 <b>BRONZE</b>	 <b>SILVER</b>	 <b>GOLD</b>	 <b>PLATINUM</b>
<b>1. Student work related to this Crosscutting Concept:</b> In this project, we tested at least two different gear ratios to explore how a change in gears affects the speed of the car.				
<b>Stability and Change:</b>  Students observe that changes in one part of a system might cause large changes in another.	<ul style="list-style-type: none"> <li>We tested our gear racer using gear setting A.</li> <li>We observed three different gear pairs between the motor and the wheel axle.</li> </ul> <input type="checkbox"/>	<ul style="list-style-type: none"> <li>We met Bronze.</li> <li>We tested our gear racer using gear setting B.</li> <li>We completed our measurements and calculations on our student worksheet.</li> </ul> <input type="checkbox"/>	<ul style="list-style-type: none"> <li>We met Silver.</li> <li>We identified which change in our gear system caused a change in our gear racer's speed.</li> </ul> <input type="checkbox"/>	<ul style="list-style-type: none"> <li>We met Gold.</li> <li>We used our observations from this experiment to propose new gear redesign ideas.</li> <li>We predicted the changes our proposed redesign would create.</li> </ul> <input type="checkbox"/>
<b>2. Student work related to this Practice:</b> In this project, we considered multiple redesign ideas before deciding on our final solution.				
<b>Engaging in Argument from Evidence:</b>  Evaluate competing design solutions based on jointly developed and agreed-upon design criteria.	<ul style="list-style-type: none"> <li>We discussed as a group all of the redesign questions provided to us on our student worksheet.</li> <li>We came up with one possible solution.</li> </ul> <input type="checkbox"/>	<ul style="list-style-type: none"> <li>We met Bronze.</li> <li>We discussed and agreed upon our redesign goal.</li> <li>We discussed at least two solutions to meet our design goal.</li> <li>We tested two solutions.</li> </ul> <input type="checkbox"/>	<ul style="list-style-type: none"> <li>We met Silver.</li> <li>We created a measurable goal (a turn angle, a speed, a slope angle, etc.)</li> <li>We tested our solutions.</li> <li>We used evidence from our tests in a discussion about which solution was the best.</li> </ul> <input type="checkbox"/>	<ul style="list-style-type: none"> <li>We met Gold.</li> <li>We concluded our discussion and picked the best design solution to meet our measurable goals.</li> </ul> <input type="checkbox"/>
<b>3. Student work related to this Practice:</b> In this project, we redesigned our gear racer. We communicated our redesign focus and the test results that evaluated the new design's performance.				
<b>Obtaining, Evaluating, and Communicating Information:</b>  Communicate scientific and/or technical information about a proposed object in writing and/or through oral presentation.	<ul style="list-style-type: none"> <li>We documented our redesign process with an outline that included our redesign focus, our ideas, and our test results.</li> </ul> <input type="checkbox"/>	<ul style="list-style-type: none"> <li>We met Bronze.</li> <li>We added sketches to our outline( or digital photos / videos).</li> <li>We added a data table to organize our test results.</li> </ul> <input type="checkbox"/>	<ul style="list-style-type: none"> <li>We met Silver.</li> <li>We added a clear conclusion.</li> <li>We added more descriptive notes to our document or presentation.</li> <li>We rehearsed our presentation.</li> </ul> <input type="checkbox"/>	<ul style="list-style-type: none"> <li>We met Gold.</li> <li>We included a rough draft of our outline.</li> <li>We improved our work based on input from others.</li> <li>We shared our final document or presentation.</li> </ul> <input type="checkbox"/>
Notes:				

## Catapult



### The Assignment





An essential feature of medieval warfare was siege weapons. These include the siege tower, covered ladders, and the catapult, perhaps the most fearsome weapon of them all. From a safe distance, beyond the range of the archers in the castle, the catapult could fling rocks high into the air so that they crashed down onto the walls causing them to crumble. The catapults could also be used to throw burning bales of straw to set the wooden and thatched buildings in the castle grounds on fire. There were several different types of catapults. Some used large blocks of stone as a counter weight to cause a long arm to fling rocks onto and over the castle walls. Others used the energy stored in twisted rope for the same effect.

**Your task is to design and build a realistic catapult that can throw small rocks as far and accurate as possible.**

## Problem Solving Activity: \_\_\_\_\_

Name(s): \_\_\_\_\_

Date: \_\_\_\_\_

	 <b>BRONZE</b>	 <b>SILVER</b>	 <b>GOLD</b>	 <b>PLATINUM</b>
<b>GOALS</b>  <b>Design Brief:</b>  Understand the problem, develop prototypes to solve it, test those prototypes and revise your design to make it better.	<ul style="list-style-type: none"> <li>• Our design met the goals or criteria defined by the activity.</li> </ul> <input type="checkbox"/>	<ul style="list-style-type: none"> <li>• We met Bronze</li> <li>• We tested our prototype multiple times.</li> <li>• We made at least one improvement.</li> </ul> <input type="checkbox"/>	<ul style="list-style-type: none"> <li>• We met Silver</li> <li>• We made at least two improvements.</li> </ul> <input type="checkbox"/>	<ul style="list-style-type: none"> <li>• We met Gold</li> <li>• We tested at least two different designs.</li> <li>• We picked the best design, tested it, and made several improvements.</li> </ul> <input type="checkbox"/>
<b>Creativity:</b>  Come up with inventive and creative solutions to problems. Consider multiple solutions.	<ul style="list-style-type: none"> <li>• We started the activity and have at least one possible solution that looks reasonable.</li> </ul> <input type="checkbox"/>	<ul style="list-style-type: none"> <li>• We brainstormed two to three ideas.</li> <li>• We built a working model to solve the problem.</li> </ul> <input type="checkbox"/>	<ul style="list-style-type: none"> <li>• We brainstormed more than three ideas.</li> <li>• We built an effective model to solve the problem.</li> </ul> <input type="checkbox"/>	<ul style="list-style-type: none"> <li>• We brainstormed many ideas.</li> <li>• We built and tested prototypes for at least two ideas.</li> <li>• We built an original and effective model that solves the problem.</li> </ul> <input type="checkbox"/>
<b>Collaboration:</b>  Work is shared effectively and the team encourages and helps each other.	<ul style="list-style-type: none"> <li>• We sometimes worked together well but some team members did more work than others or we needed help from the teacher to resolve some disagreements.</li> </ul> <input type="checkbox"/>	<ul style="list-style-type: none"> <li>• We generally worked together well, providing help and support to each other.</li> <li>• The work was shared fairly evenly among the group members.</li> </ul> <input type="checkbox"/>	<ul style="list-style-type: none"> <li>• We worked together well, providing help and support to each other.</li> <li>• The work tasks were shared evenly.</li> <li>• We addressed issues that arose.</li> </ul> <input type="checkbox"/>	<ul style="list-style-type: none"> <li>• We worked together unusually well, overcoming unexpected obstacles by working together as a team.</li> <li>• We actively helped and supported each other.</li> <li>• We addressed issues that arose with honest, constructive feedback.</li> </ul> <input type="checkbox"/>
<b>Notes:</b>  _____ _____ _____				

# Catapult

## Objectives

Applying knowledge of:

- Simple machines, mechanisms and structures
- Engineering design
- Communicating and team working
- Applying principles of safety and product reliability

## Other Materials Required (Optional)

- Materials for powering the mechanism – weights, string, elastic bands
- Materials for to ensure safety e.g. handle, locking mechanism
- Materials for trying out the catapult e.g. small balls of expanded polystyrene
- Tape measure

## Motivation

To help in the design process, instruct the students to look at the picture on the front of the unit and read the accompanying text.

Alternatively, let the students search the Internet to learn more about the appearance, shape and form of ballistas, mangonels and trebuchets.

Discuss the constraints and functions the ancient engineers would have had to take into account.

## While the activity is in progress, encourage the students to relate their knowledge, skills and understanding to the task at hand by asking:

- How will your catapult work? Will it use counterweights, twisted string or rubber bands?
- What sort of structure will you use to support the throwing mechanism?
- How will you ensure that the throwing action does not cause the catapult to fall over?
- How will you ensure that the catapult can be easily moved from place to place?
- What will you use for ammunition?

## When the activity is almost finished, encourage the students to reflect on both the product that they have produced and the processes they have used by encouraging the students to:

- Carry out tests to evaluate the performance of the catapult:
  - What is its range?
  - What is its accuracy?
  - What is its consistency?
- Record their design by drawing it or taking digital photos of it
- Add notes describing the way the model works and how this might be improved to get a better performance
- Describe how to ensure safe use of the model
- Write briefly on what went well in their design task and what they could have done to improve it

## Need help?

Look at:

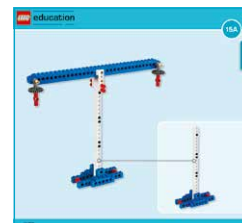

Beam balance

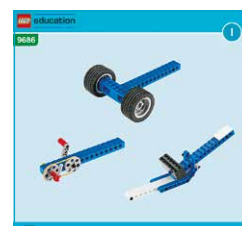

Principle models building instructions booklet for lever



**Suggested Model Solution**

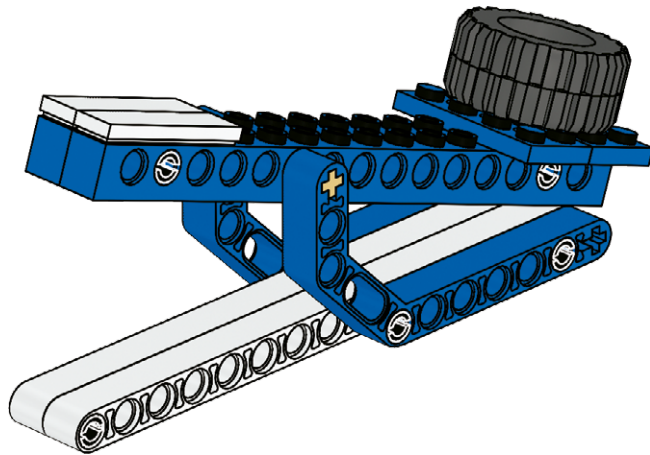
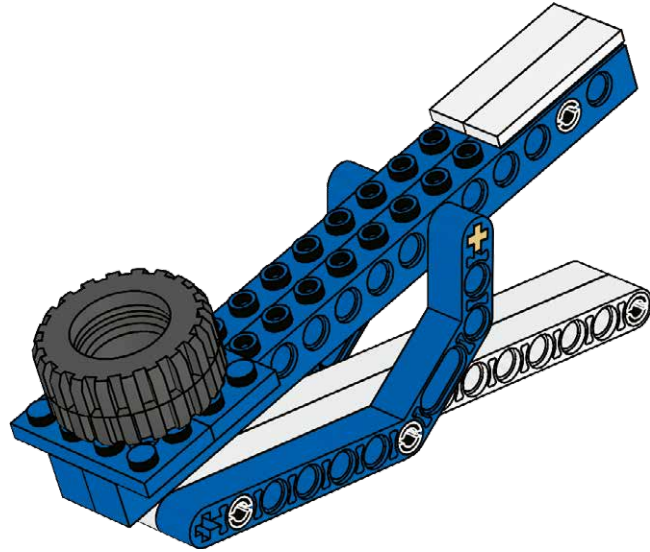

Observation Checklist Part 1		Name(s)									
<b>Science and Engineering Practices</b> <b>Grade 6-8</b>  Use the Bronze (1), Silver (2), Gold (3), and Platinum (4) proficiency level descriptions, or another assessment scale that is relevant to your school context.											
<b>Practice 1: I observed students asking questions</b>											
a	to seek more information.										
b	to seek evidence for a claim.										
c	to challenge a claim or interpretation of data.										
d	to identify and understand independent and dependent variables.										
e	that can be investigated in this class.										
<b>Practice 2: I observed students developing and/or using a model</b>											
a	to explore its limitations.										
b	to explore what happens when parts of the model are changed.										
c	to show the relationship between variables.										
d	to make predictions.										
e	to generate data about what they are designing or investigating.										
<b>Practice 3: I observed students planning and carrying out investigations</b>											
a	that included independent and dependent variables and controls.										
b	that included appropriate measurement and recording tools.										
c	that tested the accuracy of various methods for collecting data.										
d	to collect data to answer a scientific question or test a design solution.										
e	to test the performance of a design under a range of conditions.										
<b>Practice 4: I observed students analyzing and interpreting data</b>											
a	by constructing graphs.										
b	to identify linear and non-linear relationships.										
c	to distinguish between cause and effect vs. correlational relationships.										
d	by using statistics and probability such as mean and percentage.										
e	to determine similarities and differences in findings.										
f	to determine a way to optimize their solution to a design problem.										
Notes:											

Observation Checklist Part 2		Name(s)									
<b>Science and Engineering Practices Grade 6-8</b>											
Use the Bronze (1), Silver (2), Gold (3), and Platinum (4) proficiency level descriptions, or another assessment scale that is relevant to your school context.											
<b>Practice 5: I observed students using mathematics and computational thinking</b>											
a	by including mathematical representations in their explanations and design solutions.										
b	by using an algorithm to solve a problem.										
c	by using concepts such as ratio, rate, percent, basic operations, or simple algebra.										
<b>Practice 6: I observed students constructing explanations and design solutions</b>											
a	that included quantitative and qualitative relationships.										
b	that are based on scientific ideas, laws and theories.										
c	that connect scientific ideas, laws, and theories to their own observations.										
d	that apply scientific ideas, laws, and theories.										
e	to help optimize design ideas while making tradeoffs and revisions.										
<b>Practice 7: I observed students engaging in arguments from evidence</b>											
a	that compare and critique two arguments on the same topic.										
b	while respectfully providing and receiving critiques using appropriate evidence.										
c	while presenting oral or written statements supported by evidence.										
d	while evaluating different design solutions based on agreed-upon criteria and constraints.										
<b>Practice 8: I observed students evaluating and communicating information</b>											
a	when they read scientific text adapted for the classroom.										
b	when they read or wrote information in combinations of text, graphs, diagrams, and other media.										
c	when they created presentations about their investigations and/or design solutions.										
Notes:											

## Hand Cart



### The Assignment





Hand carts are often used to move small loads in confined places. One area of use is in libraries to move rows of heavy books from one area to another. They need to be able to carry quite heavy loads, so they must be stable and highly maneuverable.

**Your task is to design and build a hand cart that could be used in a large library to move as many books and in as confined a space as possible.**

## Problem Solving Activity: \_\_\_\_\_

Name(s): \_\_\_\_\_

Date: \_\_\_\_\_

	 <b>BRONZE</b>	 <b>SILVER</b>	 <b>GOLD</b>	 <b>PLATINUM</b>
<p><b>GOALS</b></p>	<p><b>Design Brief:</b></p> <p>Understand the problem, develop prototypes to solve it, test those prototypes and revise your design to make it better.</p>	<p>• Our design met the goals or criteria defined by the activity.</p>	<p>• We met Bronze</p> <p>• We tested our prototype multiple times.</p> <p>• We made at least one improvement.</p>	<p>• We met Silver</p> <p>• We made at least two improvements.</p>
<p><b>Creativity:</b></p> <p>Come up with inventive and creative solutions to problems. Consider multiple solutions.</p>	<p>• We met Gold</p> <p>• We tested at least two different designs.</p> <p>• We picked the best design, tested it, and made several improvements.</p>	<p>• We started the activity and have at least one possible solution that looks reasonable.</p>	<p>• We brainstormed two to three ideas.</p> <p>• We built a working model to solve the problem.</p>	<p>• We brainstormed more than three ideas.</p> <p>• We built an effective model to solve the problem.</p>
<p><b>Collaboration:</b></p> <p>Work is shared effectively and the team encourages and helps each other.</p>	<p>• We brainstormed many ideas.</p> <p>• We built and tested prototypes for at least two ideas.</p> <p>• We built an original and effective model that solves the problem.</p>	<p>• We sometimes worked together well but some team members did more work than others or we needed help from the teacher to resolve some disagreements.</p>	<p>• We generally worked together well, providing help and support to each other.</p> <p>• The work was shared fairly evenly among the group members.</p>	<p>• We worked together well, providing help and support to each other.</p> <p>• The work tasks were shared evenly.</p> <p>• We addressed issues that arose.</p>

Notes: \_\_\_\_\_

# Hand Cart

## Objectives

Applying knowledge of:

- Simple machines, mechanisms and structures
- Engineering design
- Communicating and team working
- Applying principles of safety and product reliability

## Other Materials Required (Optional)

- Materials to ensure safety e.g. grating, bars, soft edges
- Spare LEGO® bricks as books e.g. the LEGO weight element

## Motivation

To help in the design process, instruct the students to look at the picture on the front of the unit and read the accompanying text.

Alternatively, let the students search the Internet to learn more about the appearance, shape and handling of a hand cart.

Discuss the constraints and functions they will have to take into account.

## While the activity is in progress, encourage the students to relate their knowledge, skills and understanding to the task at hand by asking:

- How will your hand cart work?
- What sort of structure will you use to support the steering mechanism?
- What sort of steering mechanism will you use?
- What sort of structure will you use to hold the books?
- How will you ensure that the hand cart is maneuverable?
- How will you ensure that the hand cart is stable?
- How will ensure that the hand cart is safe to use?

## When the activity is almost finished, encourage the students to reflect on both the product that they have produced and the processes they have used by encouraging the students to:

- Carry out tests to evaluate the performance of the hand cart:
  - How much can it carry?
  - How easy is it to steer?
  - How maneuverable it is??
- Record their design by drawing it or taking digital photos of it
- Add notes describing the way the model works and how this might be improved to get better performance
- Describe how to ensure safe use of the model
- Write briefly on what went well in their design task and what they could have done to improve it

## Need help?

Look at:



Ramp



Principle models building instructions booklet for wheel and axle

### Suggested Model Solution

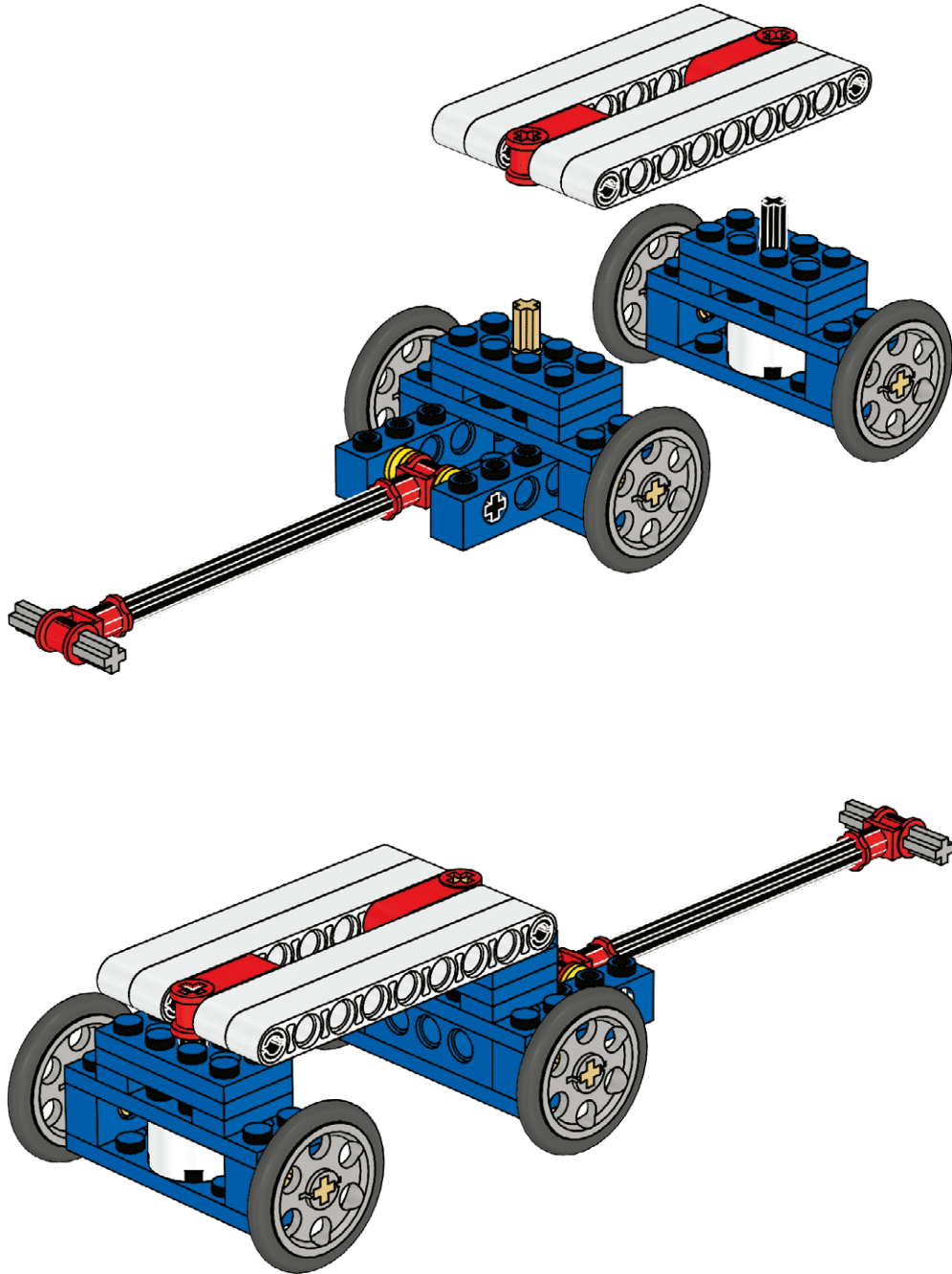

Observation Checklist Part 1		Name(s)									
<b>Science and Engineering Practices</b> <b>Grade 6-8</b>  Use the Bronze (1), Silver (2), Gold (3), and Platinum (4) proficiency level descriptions, or another assessment scale that is relevant to your school context.											
<b>Practice 1: I observed students asking questions</b>											
a	to seek more information.										
b	to seek evidence for a claim.										
c	to challenge a claim or interpretation of data.										
d	to identify and understand independent and dependent variables.										
e	that can be investigated in this class.										
<b>Practice 2: I observed students developing and/or using a model</b>											
a	to explore its limitations.										
b	to explore what happens when parts of the model are changed.										
c	to show the relationship between variables.										
d	to make predictions.										
e	to generate data about what they are designing or investigating.										
<b>Practice 3: I observed students planning and carrying out investigations</b>											
a	that included independent and dependent variables and controls.										
b	that included appropriate measurement and recording tools.										
c	that tested the accuracy of various methods for collecting data.										
d	to collect data to answer a scientific question or test a design solution.										
e	to test the performance of a design under a range of conditions.										
<b>Practice 4: I observed students analyzing and interpreting data</b>											
a	by constructing graphs.										
b	to identify linear and non-linear relationships.										
c	to distinguish between cause and effect vs. correlational relationships.										
d	by using statistics and probability such as mean and percentage.										
e	to determine similarities and differences in findings.										
f	to determine a way to optimize their solution to a design problem.										
Notes:											



<b>Observation Checklist Part 2</b>  <b>Science and Engineering Practices</b> <b>Grade 6-8</b>  Use the Bronze (1), Silver (2), Gold (3), and Platinum (4) proficiency level descriptions, or another assessment scale that is relevant to your school context.		Name(s)									
<b>Practice 5: I observed students using mathematics and computational thinking</b>											
a	by including mathematical representations in their explanations and design solutions.										
b	by using an algorithm to solve a problem.										
c	by using concepts such as ratio, rate, percent, basic operations, or simple algebra.										
<b>Practice 6: I observed students constructing explanations and design solutions</b>											
a	that included quantitative and qualitative relationships.										
b	that are based on scientific ideas, laws and theories.										
c	that connect scientific ideas, laws, and theories to their own observations.										
d	that apply scientific ideas, laws, and theories.										
e	to help optimize design ideas while making tradeoffs and revisions.										
<b>Practice 7: I observed students engaging in arguments from evidence</b>											
a	that compare and critique two arguments on the same topic.										
b	while respectfully providing and receiving critiques using appropriate evidence.										
c	while presenting oral or written statements supported by evidence.										
d	while evaluating different design solutions based on agreed-upon criteria and constraints.										
<b>Practice 8: I observed students evaluating and communicating information</b>											
a	when they read scientific text adapted for the classroom.										
b	when they read or wrote information in combinations of text, graphs, diagrams, and other media.										
c	when they created presentations about their investigations and/or design solutions.										
Notes:											

## Winch



### The Assignment





There are many situations in which it is useful to apply a strong pulling force. This is particularly true on sailing boats. The device that is used for this is the winch. These can be small hand operated devices used for raising and lowering sails, and for altering the angle of the sail to the wind. More powerful motor driven winches are used for raising and lowering the anchor and even moving the boat itself along the slipway. They need to be powerful because boats are heavy and reliable as it would be very dangerous if the winch failed and the boat moved uncontrollably back into the water.

**Your task is to design and build a motorized winch to be used to pull a boat out of the water onto a slipway.**

## Problem Solving Activity: \_\_\_\_\_

Name(s): \_\_\_\_\_

Date: \_\_\_\_\_

GOALS	 <b>BRONZE</b>	 <b>SILVER</b>	 <b>GOLD</b>	 <b>PLATINUM</b>
<p><b>Design Brief:</b></p> <p>Understand the problem, develop prototypes to solve it, test those prototypes and revise your design to make it better.</p>	<ul style="list-style-type: none"> <li>• Our design met the goals or criteria defined by the activity.</li> </ul> <p style="text-align: center;"><input type="checkbox"/></p>	<ul style="list-style-type: none"> <li>• We met Bronze</li> <li>• We tested our prototype multiple times.</li> <li>• We made at least one improvement.</li> </ul> <p style="text-align: center;"><input type="checkbox"/></p>	<ul style="list-style-type: none"> <li>• We met Silver</li> <li>• We made at least two improvements.</li> </ul> <p style="text-align: center;"><input type="checkbox"/></p>	<ul style="list-style-type: none"> <li>• We met Gold</li> <li>• We tested at least two different designs.</li> <li>• We picked the best design, tested it, and made several improvements.</li> </ul> <p style="text-align: center;"><input type="checkbox"/></p>
<p><b>Creativity:</b></p> <p>Come up with inventive and creative solutions to problems. Consider multiple solutions.</p>	<ul style="list-style-type: none"> <li>• We started the activity and have at least one possible solution that looks reasonable.</li> </ul> <p style="text-align: center;"><input type="checkbox"/></p>	<ul style="list-style-type: none"> <li>• We brainstormed two to three ideas.</li> <li>• We built a working model to solve the problem.</li> </ul> <p style="text-align: center;"><input type="checkbox"/></p>	<ul style="list-style-type: none"> <li>• We brainstormed more than three ideas.</li> <li>• We built an effective model to solve the problem.</li> </ul> <p style="text-align: center;"><input type="checkbox"/></p>	<ul style="list-style-type: none"> <li>• We brainstormed many ideas.</li> <li>• We built and tested prototypes for at least two ideas.</li> <li>• We built an original and effective model that solves the problem.</li> </ul> <p style="text-align: center;"><input type="checkbox"/></p>
<p><b>Collaboration:</b></p> <p>Work is shared effectively and the team encourages and helps each other.</p>	<ul style="list-style-type: none"> <li>• We sometimes worked together well but some team members did more work than others or we needed help from the teacher to resolve some disagreements.</li> </ul> <p style="text-align: center;"><input type="checkbox"/></p>	<ul style="list-style-type: none"> <li>• We generally worked together well, providing help and support to each other.</li> <li>• The work was shared fairly evenly among the group members.</li> </ul> <p style="text-align: center;"><input type="checkbox"/></p>	<ul style="list-style-type: none"> <li>• We worked together well, providing help and support to each other.</li> <li>• The work tasks were shared evenly.</li> <li>• We addressed issues that arose.</li> </ul> <p style="text-align: center;"><input type="checkbox"/></p>	<ul style="list-style-type: none"> <li>• We worked together unusually well, overcoming unexpected obstacles by working together as a team.</li> <li>• We actively helped and supported each other.</li> <li>• We addressed issues that arose with honest, constructive feedback.</li> </ul> <p style="text-align: center;"><input type="checkbox"/></p>

Notes:

# Winch

## Objectives

Applying knowledge of:

- Simple machines, mechanisms and structures
- Powered machines
- Engineering design
- Communicating and team working
- Applying principles of safety and product reliability

## Other Materials Required (Optional)

- Materials to ensure safety e.g. gate, fence, barrier, lights
- Materials for making a slipway e.g. a plank or a piece of cardboard
- Spare LEGO® bricks to build or to use as boats

## Motivation

To help in the design process, instruct the students to look at the picture on the front of the unit and read the accompanying text. Alternatively, let the students search the Internet to learn more about the appearance, structure and function of different sorts of motorized winch systems used to haul or launch boats in different parts of the world. Discuss the constraints and functions the ancient engineers would have had to take into account.

## While the activity is in progress, encourage the students to relate their knowledge, skills and understanding to the task at hand by asking:

- How will your winch work?
- What sort of structure will you use to support the motor?
- What sort of structure will you use to hold the cable?
- How will you attach the cable to the boat?
- How will you ensure that the winch doesn't pull too fast?
- How will you ensure that the winch doesn't pull too slowly?
- How will you ensure that the winch is powerful enough?
- How will you ensure that the winch will be able to launch boats as well as pull them from the water?

## When the activity is almost finished, encourage the students to reflect on both the product that they have produced and the processes they have used by encouraging the students to:

- Carry out tests to evaluate the performance of the winch:
  - What is the largest load it can move?
  - Does it work well both ways – hauling and launching?
  - Does it work reliably, without slip?
- Record their design by drawing it or taking digital photos of it
- Add notes describing the way the model works and how this might be improved to get better performance
- Describe how to ensure safe use of the model
- Write briefly on what went well in their design task and what they could have done to improve it

◀ **Need help?**  
Look at:

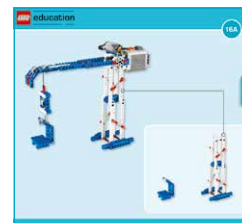

Tower crane

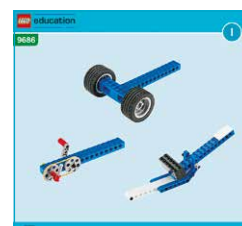

Principle models building instructions booklet for pulley

### Suggested Model Solution

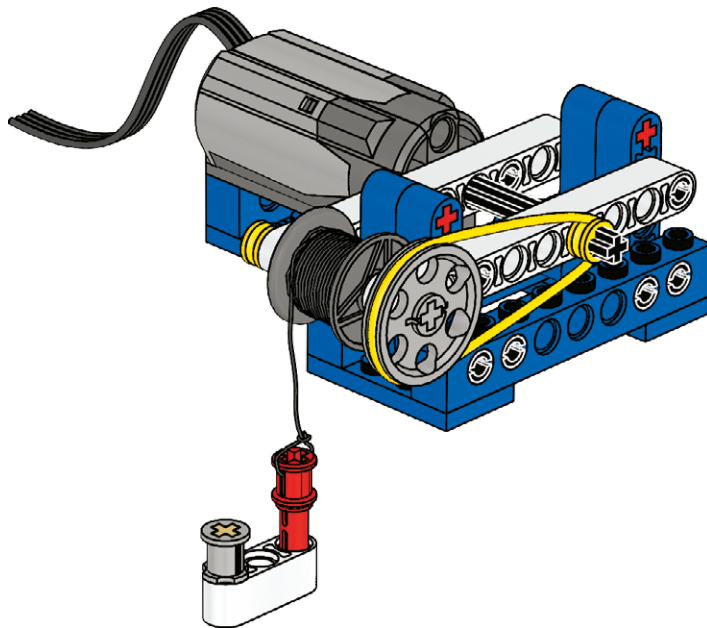
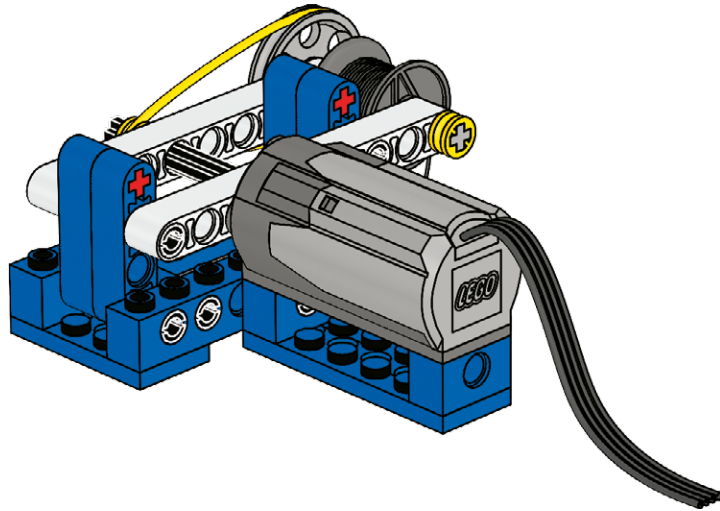

Observation Checklist Part 1		Name(s)									
<b>Science and Engineering Practices</b> <b>Grade 6-8</b>  Use the Bronze (1), Silver (2), Gold (3), and Platinum (4) proficiency level descriptions, or another assessment scale that is relevant to your school context.											
<b>Practice 1: I observed students asking questions</b>											
a	to seek more information.										
b	to seek evidence for a claim.										
c	to challenge a claim or interpretation of data.										
d	to identify and understand independent and dependent variables.										
e	that can be investigated in this class.										
<b>Practice 2: I observed students developing and/or using a model</b>											
a	to explore its limitations.										
b	to explore what happens when parts of the model are changed.										
c	to show the relationship between variables.										
d	to make predictions.										
e	to generate data about what they are designing or investigating.										
<b>Practice 3: I observed students planning and carrying out investigations</b>											
a	that included independent and dependent variables and controls.										
b	that included appropriate measurement and recording tools.										
c	that tested the accuracy of various methods for collecting data.										
d	to collect data to answer a scientific question or test a design solution.										
e	to test the performance of a design under a range of conditions.										
<b>Practice 4: I observed students analyzing and interpreting data</b>											
a	by constructing graphs.										
b	to identify linear and non-linear relationships.										
c	to distinguish between cause and effect vs. correlational relationships.										
d	by using statistics and probability such as mean and percentage.										
e	to determine similarities and differences in findings.										
f	to determine a way to optimize their solution to a design problem.										
Notes:											

Observation Checklist Part 2		Name(s)									
<b>Science and Engineering Practices Grade 6-8</b>											
Use the Bronze (1), Silver (2), Gold (3), and Platinum (4) proficiency level descriptions, or another assessment scale that is relevant to your school context.											
<b>Practice 5: I observed students using mathematics and computational thinking</b>											
a	by including mathematical representations in their explanations and design solutions.										
b	by using an algorithm to solve a problem.										
c	by using concepts such as ratio, rate, percent, basic operations, or simple algebra.										
<b>Practice 6: I observed students constructing explanations and design solutions</b>											
a	that included quantitative and qualitative relationships.										
b	that are based on scientific ideas, laws and theories.										
c	that connect scientific ideas, laws, and theories to their own observations.										
d	that apply scientific ideas, laws, and theories.										
e	to help optimize design ideas while making tradeoffs and revisions.										
<b>Practice 7: I observed students engaging in arguments from evidence</b>											
a	that compare and critique two arguments on the same topic.										
b	while respectfully providing and receiving critiques using appropriate evidence.										
c	while presenting oral or written statements supported by evidence.										
d	while evaluating different design solutions based on agreed-upon criteria and constraints.										
<b>Practice 8: I observed students evaluating and communicating information</b>											
a	when they read scientific text adapted for the classroom.										
b	when they read or wrote information in combinations of text, graphs, diagrams, and other media.										
c	when they created presentations about their investigations and/or design solutions.										
Notes:											

## Merry-go-round



### The Assignment

Parks often contain equipment to be used by children – swings, slides, climbing frames and merry-go-rounds. They are exciting, exhilarating and fun. It is important that the safety features do not spoil the excitement and it is important that the excitement isn't too dangerous.





**Your task is to design and build a powered merry-go-round that is safe and exciting to ride for at least two children.**



## Problem Solving Activity: \_\_\_\_\_

Name(s): \_\_\_\_\_

Date: \_\_\_\_\_

GOALS	 <b>BRONZE</b>	 <b>SILVER</b>	 <b>GOLD</b>	 <b>PLATINUM</b>
<p><b>Design Brief:</b></p> <p>Understand the problem, develop prototypes to solve it, test those prototypes and revise your design to make it better.</p>	<ul style="list-style-type: none"> <li>• Our design met the goals or criteria defined by the activity.</li> </ul> <p style="text-align: center;"><input type="checkbox"/></p>	<ul style="list-style-type: none"> <li>• We met Bronze</li> <li>• We tested our prototype multiple times.</li> <li>• We made at least one improvement.</li> </ul> <p style="text-align: center;"><input type="checkbox"/></p>	<ul style="list-style-type: none"> <li>• We met Silver</li> <li>• We made at least two improvements.</li> </ul> <p style="text-align: center;"><input type="checkbox"/></p>	<ul style="list-style-type: none"> <li>• We met Gold</li> <li>• We tested at least two different designs.</li> <li>• We picked the best design, tested it, and made several improvements.</li> </ul> <p style="text-align: center;"><input type="checkbox"/></p>
<p><b>Creativity:</b></p> <p>Come up with inventive and creative solutions to problems. Consider multiple solutions.</p>	<ul style="list-style-type: none"> <li>• We started the activity and have at least one possible solution that looks reasonable.</li> </ul> <p style="text-align: center;"><input type="checkbox"/></p>	<ul style="list-style-type: none"> <li>• We brainstormed two to three ideas.</li> <li>• We built a working model to solve the problem.</li> </ul> <p style="text-align: center;"><input type="checkbox"/></p>	<ul style="list-style-type: none"> <li>• We brainstormed more than three ideas.</li> <li>• We built an effective model to solve the problem.</li> </ul> <p style="text-align: center;"><input type="checkbox"/></p>	<ul style="list-style-type: none"> <li>• We brainstormed many ideas.</li> <li>• We built and tested prototypes for at least two ideas.</li> <li>• We built an original and effective model that solves the problem.</li> </ul> <p style="text-align: center;"><input type="checkbox"/></p>
<p><b>Collaboration:</b></p> <p>Work is shared effectively and the team encourages and helps each other.</p>	<ul style="list-style-type: none"> <li>• We sometimes worked together well but some team members did more work than others or we needed help from the teacher to resolve some disagreements.</li> </ul> <p style="text-align: center;"><input type="checkbox"/></p>	<ul style="list-style-type: none"> <li>• We generally worked together well, providing help and support to each other.</li> <li>• The work was shared fairly evenly among the group members.</li> </ul> <p style="text-align: center;"><input type="checkbox"/></p>	<ul style="list-style-type: none"> <li>• We worked together well, providing help and support to each other.</li> <li>• The work tasks were shared evenly.</li> <li>• We addressed issues that arose.</li> </ul> <p style="text-align: center;"><input type="checkbox"/></p>	<ul style="list-style-type: none"> <li>• We worked together unusually well, overcoming unexpected obstacles by working together as a team.</li> <li>• We actively helped and supported each other.</li> <li>• We addressed issues that arose with honest, constructive feedback.</li> </ul> <p style="text-align: center;"><input type="checkbox"/></p>

Notes:

# Merry-go-round

## Objectives

Applying knowledge of:

- Simple machines, mechanisms and structures
- Powered machines
- Engineering design
- Communicating and team working
- Applying principles of safety and product reliability

## Other Materials Required (Optional)

- Materials for decoration e.g. paper flags, streamers, banners
- Materials to ensure safety e.g. gate, fence, lights, seatbelts, handles

## Motivation

To help in the design process, instruct the students to look at the picture on the front of the unit and read the accompanying text.

Alternatively, let the students search the Internet to learn more about the appearance, structure and function of different sorts of merry-go-round played with by children in different parts of the world now and in the past. Discuss the constraints and functions they will have to take into account.

## While the activity is in progress, encourage the students to relate their knowledge, skills and understanding to the task at hand by asking:

- How will your merry-go-round work? What different sorts of parts will you need?
- How many children will be able to play on it at one time?
- What sort of structure will you use to support the children?
- What mechanism will cause the merry-go-round to move?
- How will you ensure that the merry-go-round is stable and well balanced?
- How will you ensure that the children are safe?
- How will you ensure that it looks attractive to children?

## When the activity is almost finished, encourage the students to reflect on both the product that they have produced and the processes they have used by encouraging the students to:

- Carry out tests to evaluate the performance of the merry-go-round:
  - Does it provide an exciting ride?
  - Does it provide a safe ride?
  - Does it work reliably?
- Record their design by drawing it or taking digital photos of it
- Add notes describing the way the model works and how this might be improved to get better performance
- Describe how to ensure safe use of the model
- Write briefly on what went well in their design task and what they could have done to improve it

◀ **Need help?**  
Look at:



Gear Racer

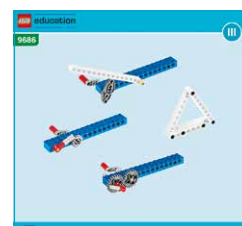

Principle models building instructions booklet for gear

### Suggested Model Solution

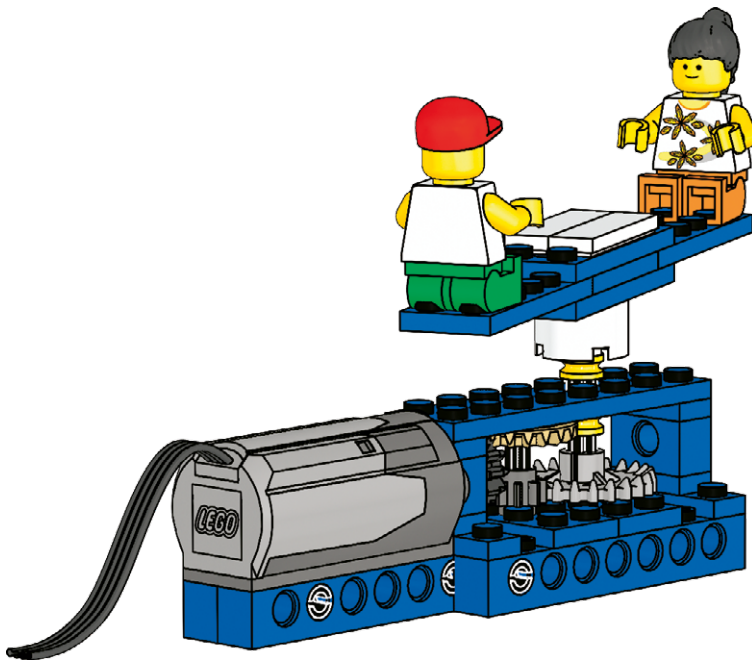
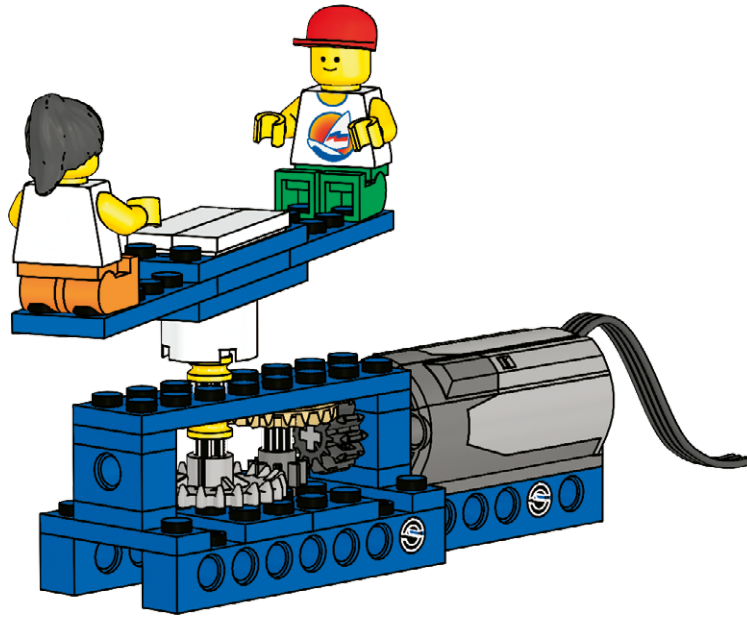

Observation Checklist Part 1		Name(s)									
<b>Science and Engineering Practices</b> <b>Grade 6-8</b>  Use the Bronze (1), Silver (2), Gold (3), and Platinum (4) proficiency level descriptions, or another assessment scale that is relevant to your school context.											
<b>Practice 1: I observed students asking questions</b>											
a	to seek more information.										
b	to seek evidence for a claim.										
c	to challenge a claim or interpretation of data.										
d	to identify and understand independent and dependent variables.										
e	that can be investigated in this class.										
<b>Practice 2: I observed students developing and/or using a model</b>											
a	to explore its limitations.										
b	to explore what happens when parts of the model are changed.										
c	to show the relationship between variables.										
d	to make predictions.										
e	to generate data about what they are designing or investigating.										
<b>Practice 3: I observed students planning and carrying out investigations</b>											
a	that included independent and dependent variables and controls.										
b	that included appropriate measurement and recording tools.										
c	that tested the accuracy of various methods for collecting data.										
d	to collect data to answer a scientific question or test a design solution.										
e	to test the performance of a design under a range of conditions.										
<b>Practice 4: I observed students analyzing and interpreting data</b>											
a	by constructing graphs.										
b	to identify linear and non-linear relationships.										
c	to distinguish between cause and effect vs. correlational relationships.										
d	by using statistics and probability such as mean and percentage.										
e	to determine similarities and differences in findings.										
f	to determine a way to optimize their solution to a design problem.										
Notes:											

Observation Checklist Part 2		Name(s)									
<b>Science and Engineering Practices Grade 6-8</b>											
Use the Bronze (1), Silver (2), Gold (3), and Platinum (4) proficiency level descriptions, or another assessment scale that is relevant to your school context.											
<b>Practice 5: I observed students using mathematics and computational thinking</b>											
a	by including mathematical representations in their explanations and design solutions.										
b	by using an algorithm to solve a problem.										
c	by using concepts such as ratio, rate, percent, basic operations, or simple algebra.										
<b>Practice 6: I observed students constructing explanations and design solutions</b>											
a	that included quantitative and qualitative relationships.										
b	that are based on scientific ideas, laws and theories.										
c	that connect scientific ideas, laws, and theories to their own observations.										
d	that apply scientific ideas, laws, and theories.										
e	to help optimize design ideas while making tradeoffs and revisions.										
<b>Practice 7: I observed students engaging in arguments from evidence</b>											
a	that compare and critique two arguments on the same topic.										
b	while respectfully providing and receiving critiques using appropriate evidence.										
c	while presenting oral or written statements supported by evidence.										
d	while evaluating different design solutions based on agreed-upon criteria and constraints.										
<b>Practice 8: I observed students evaluating and communicating information</b>											
a	when they read scientific text adapted for the classroom.										
b	when they read or wrote information in combinations of text, graphs, diagrams, and other media.										
c	when they created presentations about their investigations and/or design solutions.										
Notes:											

## Watch Tower



### The Assignment





Ornithologists study birds in the wild. They need to be in a comfortable place protected from the wind and weather. These places are often called hides because it is here that the ornithologists 'hide away' from the birds so that although they can see the birds the birds cannot see them and so behave naturally. Usually the ornithologists need to be up high to observe the birds in which case they need a watch tower with the hide at the top.

**Your task is to design and build a stabile watch tower suitable for bird watching that is as tall as possible.**

## Problem Solving Activity: \_\_\_\_\_

Name(s): \_\_\_\_\_

Date: \_\_\_\_\_

	 <b>BRONZE</b>	 <b>SILVER</b>	 <b>GOLD</b>	 <b>PLATINUM</b>
<p><b>GOALS</b></p> <p><b>Design Brief:</b> Understand the problem, develop prototypes to solve it, test those prototypes and revise your design to make it better.</p>	<ul style="list-style-type: none"> <li>• Our design met the goals or criteria defined by the activity.</li> </ul> <p style="text-align: center;"><input type="checkbox"/></p>	<ul style="list-style-type: none"> <li>• We met Bronze</li> <li>• We tested our prototype multiple times.</li> <li>• We made at least one improvement.</li> </ul> <p style="text-align: center;"><input type="checkbox"/></p>	<ul style="list-style-type: none"> <li>• We met Silver</li> <li>• We made at least two improvements.</li> </ul> <p style="text-align: center;"><input type="checkbox"/></p>	<ul style="list-style-type: none"> <li>• We met Gold</li> <li>• We tested at least two different designs.</li> <li>• We picked the best design, tested it, and made several improvements.</li> </ul> <p style="text-align: center;"><input type="checkbox"/></p>
<p><b>Creativity:</b> Come up with inventive and creative solutions to problems. Consider multiple solutions.</p>	<ul style="list-style-type: none"> <li>• We started the activity and have at least one possible solution that looks reasonable.</li> </ul> <p style="text-align: center;"><input type="checkbox"/></p>	<ul style="list-style-type: none"> <li>• We brainstormed two to three ideas.</li> <li>• We built a working model to solve the problem.</li> </ul> <p style="text-align: center;"><input type="checkbox"/></p>	<ul style="list-style-type: none"> <li>• We brainstormed more than three ideas.</li> <li>• We built an effective model to solve the problem.</li> </ul> <p style="text-align: center;"><input type="checkbox"/></p>	<ul style="list-style-type: none"> <li>• We brainstormed many ideas.</li> <li>• We built and tested prototypes for at least two ideas.</li> <li>• We built an original and effective model that solves the problem.</li> </ul> <p style="text-align: center;"><input type="checkbox"/></p>
<p><b>Collaboration:</b> Work is shared effectively and the team encourages and helps each other.</p>	<ul style="list-style-type: none"> <li>• We sometimes worked together well but some team members did more work than others or we needed help from the teacher to resolve some disagreements.</li> </ul> <p style="text-align: center;"><input type="checkbox"/></p>	<ul style="list-style-type: none"> <li>• We generally worked together well, providing help and support to each other.</li> <li>• The work was shared fairly evenly among the group members.</li> </ul> <p style="text-align: center;"><input type="checkbox"/></p>	<ul style="list-style-type: none"> <li>• We worked together well, providing help and support to each other.</li> <li>• The work tasks were shared evenly.</li> <li>• We addressed issues that arose.</li> </ul> <p style="text-align: center;"><input type="checkbox"/></p>	<ul style="list-style-type: none"> <li>• We worked together unusually well, overcoming unexpected obstacles by working together as a team.</li> <li>• We actively helped and supported each other.</li> <li>• We addressed issues that arose with honest, constructive feedback.</li> </ul> <p style="text-align: center;"><input type="checkbox"/></p>

Notes:

# Watch Tower

## Objectives

Applying knowledge of:

- Simple machines, mechanisms and structures
- Engineering design
- Communicating and team working
- Applying principles of safety and product reliability

## Other Materials Required (Optional)

- Materials for camouflage
- Materials to ensure safety e.g. gate, ladder, barrier, lights

## Motivation

To help in the design process, instruct the students to look at the picture on the front of the unit and read the accompanying text. Alternatively, let the students search the Internet to learn more about the appearance, structure and function of different sorts of watch towers and hides are used by ornithologists in different parts of the world. Discuss the constraints and functions they will have to take into account.

## While the activity is in progress, encourage the students to relate their knowledge, skills and understanding to the task at hand by asking:

- How will your watch tower work? What different sorts of parts will you need?
- How will you ensure that the structure to support the hide is strong?
- How will you ensure that the structure to support the hide is stable?
- How will you ensure that the structure to support the hide does not sway in the wind?
- How will the ornithologists reach the hide?
- How will the ornithologists get their equipment into the hide?
- How will you ensure that the hide and watch tower blend into the surroundings?

## When the activity is almost finished, encourage the students to reflect on both the product that they have produced and the processes they have used by encouraging the students to:

- Carry out tests to evaluate the performance of the watch tower:
  - How well does it protect those in the hide?
  - How easy is it to use?
  - How well does it blend into the background?
  - How safe is it?
- Record their design by drawing it or taking digital photos of it
- Add notes describing the way the model works and how this might be improved to get better performance
- Describe how to ensure safe use of the model
- Write briefly on what went well in their design task and what they could have done to improve it

## Need help?

Look at:



Tower crane

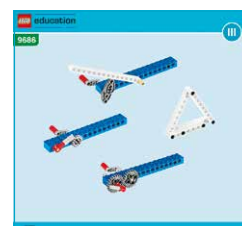

Principle models building instructions booklet for structures



### Suggested Model Solution

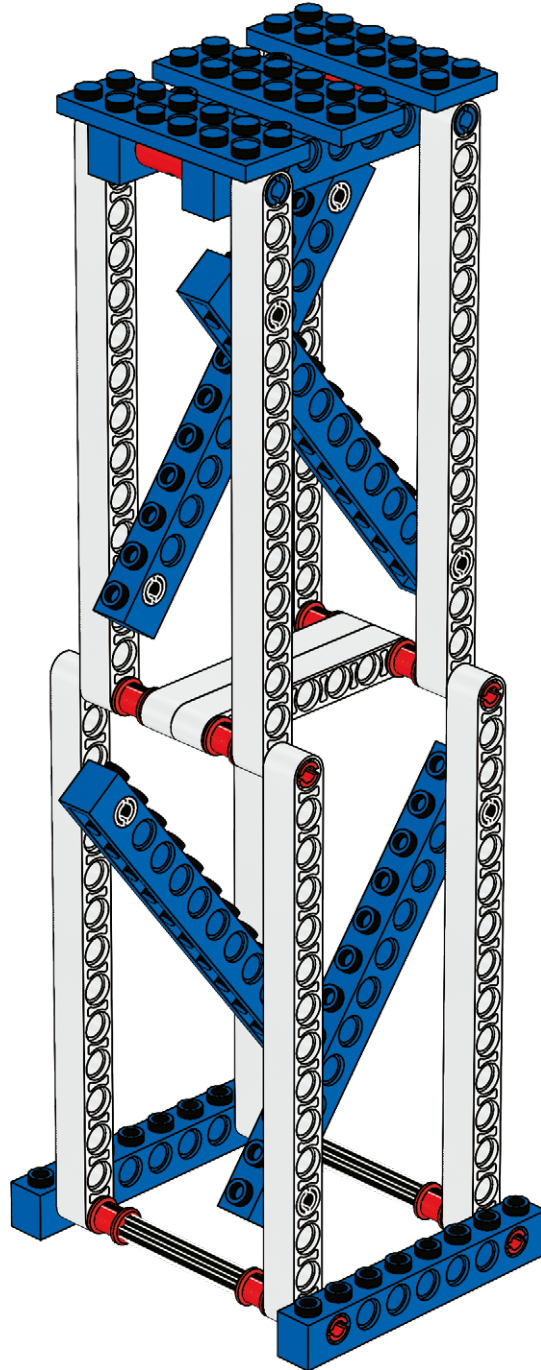

Observation Checklist Part 1		Name(s)									
<b>Science and Engineering Practices</b> <b>Grade 6-8</b>  Use the Bronze (1), Silver (2), Gold (3), and Platinum (4) proficiency level descriptions, or another assessment scale that is relevant to your school context.											
<b>Practice 1: I observed students asking questions</b>											
a	to seek more information.										
b	to seek evidence for a claim.										
c	to challenge a claim or interpretation of data.										
d	to identify and understand independent and dependent variables.										
e	that can be investigated in this class.										
<b>Practice 2: I observed students developing and/or using a model</b>											
a	to explore its limitations.										
b	to explore what happens when parts of the model are changed.										
c	to show the relationship between variables.										
d	to make predictions.										
e	to generate data about what they are designing or investigating.										
<b>Practice 3: I observed students planning and carrying out investigations</b>											
a	that included independent and dependent variables and controls.										
b	that included appropriate measurement and recording tools.										
c	that tested the accuracy of various methods for collecting data.										
d	to collect data to answer a scientific question or test a design solution.										
e	to test the performance of a design under a range of conditions.										
<b>Practice 4: I observed students analyzing and interpreting data</b>											
a	by constructing graphs.										
b	to identify linear and non-linear relationships.										
c	to distinguish between cause and effect vs. correlational relationships.										
d	by using statistics and probability such as mean and percentage.										
e	to determine similarities and differences in findings.										
f	to determine a way to optimize their solution to a design problem.										
Notes:											

Observation Checklist Part 2		Name(s)									
<b>Science and Engineering Practices</b> <b>Grade 6-8</b>  Use the Bronze (1), Silver (2), Gold (3), and Platinum (4) proficiency level descriptions, or another assessment scale that is relevant to your school context.											
<b>Practice 5: I observed students using mathematics and computational thinking</b>											
a	by including mathematical representations in their explanations and design solutions.										
b	by using an algorithm to solve a problem.										
c	by using concepts such as ratio, rate, percent, basic operations, or simple algebra.										
<b>Practice 6: I observed students constructing explanations and design solutions</b>											
a	that included quantitative and qualitative relationships.										
b	that are based on scientific ideas, laws and theories.										
c	that connect scientific ideas, laws, and theories to their own observations.										
d	that apply scientific ideas, laws, and theories.										
e	to help optimize design ideas while making tradeoffs and revisions.										
<b>Practice 7: I observed students engaging in arguments from evidence</b>											
a	that compare and critique two arguments on the same topic.										
b	while respectfully providing and receiving critiques using appropriate evidence.										
c	while presenting oral or written statements supported by evidence.										
d	while evaluating different design solutions based on agreed-upon criteria and constraints.										
<b>Practice 8: I observed students evaluating and communicating information</b>											
a	when they read scientific text adapted for the classroom.										
b	when they read or wrote information in combinations of text, graphs, diagrams, and other media.										
c	when they created presentations about their investigations and/or design solutions.										
Notes:											

## Bridge



### The Assignment





Bridges have been used since early times to cross natural barriers. These barriers can take the form of streams and rivers. Sometimes the barrier is simply a gap in the terrain – a ravine or canyon. Over time the design of bridges has evolved. In prehistoric times a simple bridge would have been a fallen tree trunk placed across a stream. Nowadays, large bridges are major engineering works requiring a team of designers and an army of construction workers.

**Your task is to design and build a large and safe bridge that will be used by people who need to cross a river.**

## Problem Solving Activity: \_\_\_\_\_

Name(s): \_\_\_\_\_

Date: \_\_\_\_\_

GOALS	 <b>BRONZE</b>	 <b>SILVER</b>	 <b>GOLD</b>	 <b>PLATINUM</b>
<p><b>Design Brief:</b></p> <p>Understand the problem, develop prototypes to solve it, test those prototypes and revise your design to make it better.</p>	<ul style="list-style-type: none"> <li>• Our design met the goals or criteria defined by the activity.</li> </ul> <p style="text-align: center;"><input type="checkbox"/></p>	<ul style="list-style-type: none"> <li>• We met Bronze</li> <li>• We tested our prototype multiple times.</li> <li>• We made at least one improvement.</li> </ul> <p style="text-align: center;"><input type="checkbox"/></p>	<ul style="list-style-type: none"> <li>• We met Silver</li> <li>• We made at least two improvements.</li> </ul> <p style="text-align: center;"><input type="checkbox"/></p>	<ul style="list-style-type: none"> <li>• We met Gold</li> <li>• We tested at least two different designs.</li> <li>• We picked the best design, tested it, and made several improvements.</li> </ul> <p style="text-align: center;"><input type="checkbox"/></p>
<p><b>Creativity:</b></p> <p>Come up with inventive and creative solutions to problems. Consider multiple solutions.</p>	<ul style="list-style-type: none"> <li>• We started the activity and have at least one possible solution that looks reasonable.</li> </ul> <p style="text-align: center;"><input type="checkbox"/></p>	<ul style="list-style-type: none"> <li>• We brainstormed two to three ideas.</li> <li>• We built a working model to solve the problem.</li> </ul> <p style="text-align: center;"><input type="checkbox"/></p>	<ul style="list-style-type: none"> <li>• We brainstormed more than three ideas.</li> <li>• We built an effective model to solve the problem.</li> </ul> <p style="text-align: center;"><input type="checkbox"/></p>	<ul style="list-style-type: none"> <li>• We brainstormed many ideas.</li> <li>• We built and tested prototypes for at least two ideas.</li> <li>• We built an original and effective model that solves the problem.</li> </ul> <p style="text-align: center;"><input type="checkbox"/></p>
<p><b>Collaboration:</b></p> <p>Work is shared effectively and the team encourages and helps each other.</p>	<ul style="list-style-type: none"> <li>• We sometimes worked together well but some team members did more work than others or we needed help from the teacher to resolve some disagreements.</li> </ul> <p style="text-align: center;"><input type="checkbox"/></p>	<ul style="list-style-type: none"> <li>• We generally worked together well, providing help and support to each other.</li> <li>• The work was shared fairly evenly among the group members.</li> </ul> <p style="text-align: center;"><input type="checkbox"/></p>	<ul style="list-style-type: none"> <li>• We worked together well, providing help and support to each other.</li> <li>• The work tasks were shared evenly.</li> <li>• We addressed issues that arose.</li> </ul> <p style="text-align: center;"><input type="checkbox"/></p>	<ul style="list-style-type: none"> <li>• We worked together unusually well, overcoming unexpected obstacles by working together as a team.</li> <li>• We actively helped and supported each other.</li> <li>• We addressed issues that arose with honest, constructive feedback.</li> </ul> <p style="text-align: center;"><input type="checkbox"/></p>

Notes:

# Bridge

## Objectives

Applying knowledge of:

- Simple machines, mechanisms and structures
- Engineering design
- Communicating and team working
- Applying principles of safety and product reliability

## Other Materials Required (Optional)

- Materials for decoration
- Materials to ensure safety e.g. gate, fence, barrier, lights

## Motivation

To help in the design process, instruct the students to look at the picture on the front of the unit and read the accompanying text. Alternatively, let the students search the Internet to learn more about the appearance, structure and function of the 4 types of bridges; beam bridge, cantilevered bridge, suspension bridge, and cable stayed bridge, from now and in the past. Discuss the constraints and functions they will have to take into account.

## While the activity is in progress, encourage the students to relate their knowledge, skills and understanding to the task at hand by asking:

- Which type of bridge will you base your model on?
- What different sorts of parts will your bridge need?
- How will you ensure that the bridge is strong?
- How will you ensure that the bridge is rigid?
- How will you ensure that the bridge is stable?
- How will you ensure that the bridge is safe to use?
- When the bridge is being used which parts will be in compression and which in tension?

## When the activity is almost finished, encourage the students to reflect on both the product that they have produced and the processes they have used by encouraging the students to:

- Carry out tests to evaluate the performance of the bridge:
  - how much load can it take before breaking?
  - much load can it take before deforming?
  - does uneven loading cause the bridge to twist or fall over?
  - will people using the bridge be in any danger?
- Record their design by drawing it or taking digital photos of it
- Add notes describing the way the model works and how this might be improved to get better performance
- Describe how to ensure safe use of the model
- Write briefly on what went well in their design task and what they could have done to improve it

## Need help?

Look at:

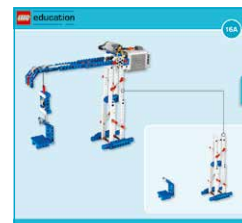

Tower crane

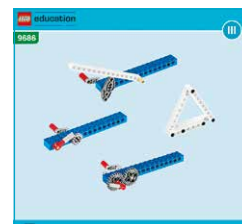

Principle models building instructions booklet for structures

### Suggested Model Solution

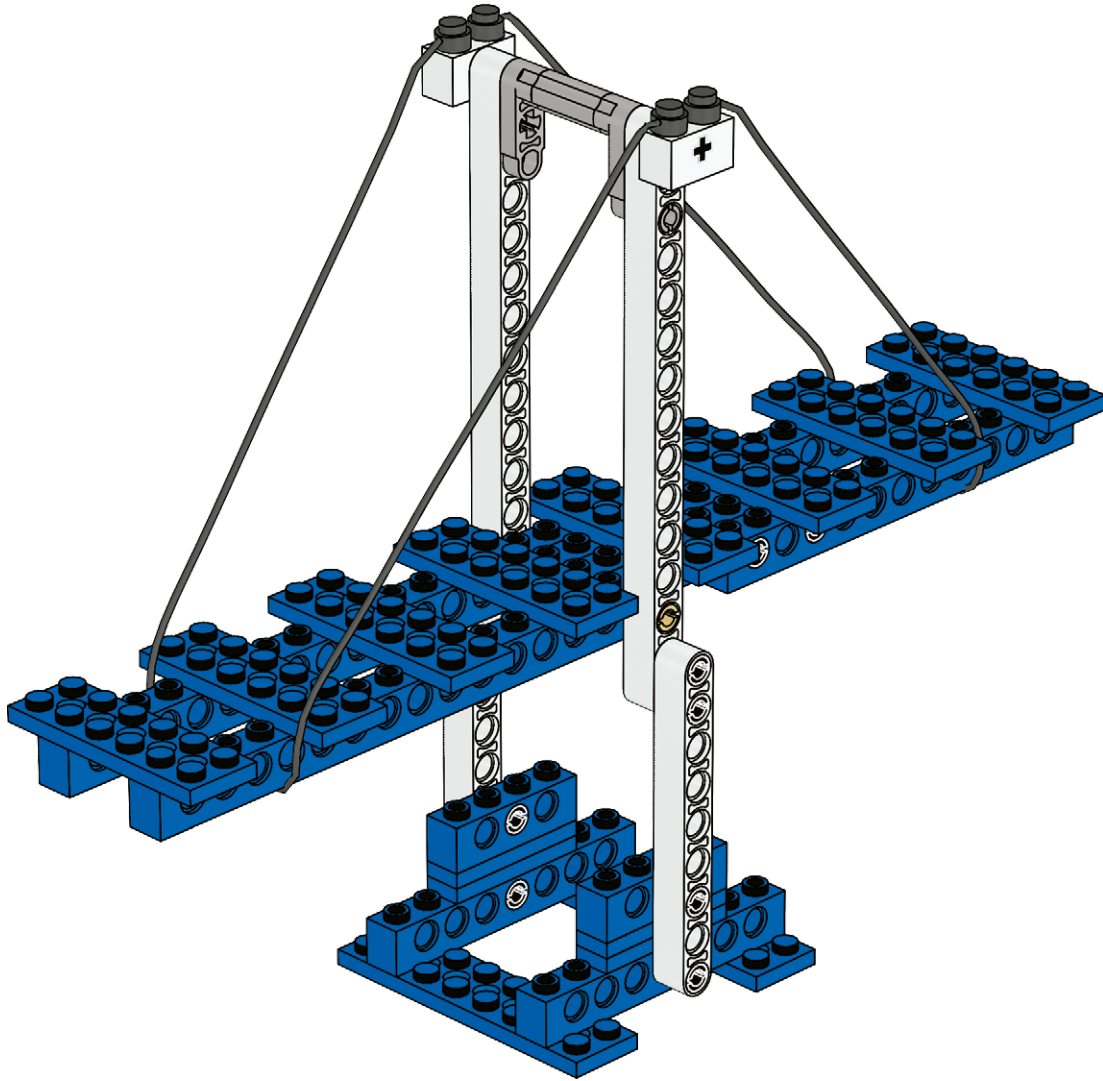

Observation Checklist Part 1		Name(s)									
<b>Science and Engineering Practices</b> <b>Grade 6-8</b>  Use the Bronze (1), Silver (2), Gold (3), and Platinum (4) proficiency level descriptions, or another assessment scale that is relevant to your school context.											
<b>Practice 1: I observed students asking questions</b>											
a	to seek more information.										
b	to seek evidence for a claim.										
c	to challenge a claim or interpretation of data.										
d	to identify and understand independent and dependent variables.										
e	that can be investigated in this class.										
<b>Practice 2: I observed students developing and/or using a model</b>											
a	to explore its limitations.										
b	to explore what happens when parts of the model are changed.										
c	to show the relationship between variables.										
d	to make predictions.										
e	to generate data about what they are designing or investigating.										
<b>Practice 3: I observed students planning and carrying out investigations</b>											
a	that included independent and dependent variables and controls.										
b	that included appropriate measurement and recording tools.										
c	that tested the accuracy of various methods for collecting data.										
d	to collect data to answer a scientific question or test a design solution.										
e	to test the performance of a design under a range of conditions.										
<b>Practice 4: I observed students analyzing and interpreting data</b>											
a	by constructing graphs.										
b	to identify linear and non-linear relationships.										
c	to distinguish between cause and effect vs. correlational relationships.										
d	by using statistics and probability such as mean and percentage.										
e	to determine similarities and differences in findings.										
f	to determine a way to optimize their solution to a design problem.										
Notes:											



Observation Checklist Part 2		Name(s)									
<b>Science and Engineering Practices Grade 6-8</b>											
Use the Bronze (1), Silver (2), Gold (3), and Platinum (4) proficiency level descriptions, or another assessment scale that is relevant to your school context.											
<b>Practice 5: I observed students using mathematics and computational thinking</b>											
a	by including mathematical representations in their explanations and design solutions.										
b	by using an algorithm to solve a problem.										
c	by using concepts such as ratio, rate, percent, basic operations, or simple algebra.										
<b>Practice 6: I observed students constructing explanations and design solutions</b>											
a	that included quantitative and qualitative relationships.										
b	that are based on scientific ideas, laws and theories.										
c	that connect scientific ideas, laws, and theories to their own observations.										
d	that apply scientific ideas, laws, and theories.										
e	to help optimize design ideas while making tradeoffs and revisions.										
<b>Practice 7: I observed students engaging in arguments from evidence</b>											
a	that compare and critique two arguments on the same topic.										
b	while respectfully providing and receiving critiques using appropriate evidence.										
c	while presenting oral or written statements supported by evidence.										
d	while evaluating different design solutions based on agreed-upon criteria and constraints.										
<b>Practice 8: I observed students evaluating and communicating information</b>											
a	when they read scientific text adapted for the classroom.										
b	when they read or wrote information in combinations of text, graphs, diagrams, and other media.										
c	when they created presentations about their investigations and/or design solutions.										
Notes:											



## Glossary

- A**
- Acceleration** The rate at which speed increases.  
If a car is accelerating it is moving faster.
- Average speed** The average rate at which an object moves.  
Average speed can be calculated using this formula:
- $$\text{Average speed} = \frac{\text{Distance}}{\text{Time}}$$
- Axle** A rod through the center of a wheel, or through different parts of a cam. It transmits force, via a transmission device, from an engine to the wheel in a car or from your arm via the wheel to the axle if you are winding up a bucket on a rope.
- B**
- Balanced force** An object is balanced and does not move when all the forces acting on it are equal and opposite. See also Equilibrium.
- Belt** A continuous band stretched around two pulley wheels so one can turn the other. It is usually designed to slip if the follower pulley suddenly stops turning.
- C**
- Cams** A non-circular wheel that rotates and moves a follower. It converts the rotary movement of the cam into reciprocating or oscillating movement of the follower. Sometimes a circular wheel mounted off-center on a shaft is used as a cam.
- Compression forces** Forces in a structure that push in opposite directions, trying to squash the structure.
- Control mechanism** A mechanism that regulates an action automatically.  
A ratchet stops a gear from turning the wrong way.
- Counter balance** A force often provided by the weight of an object you use to reduce or remove the effects of another force. A crane uses a large concrete block on the short arm of its jib to counter the unbalancing effect of the load of the other longer arm.
- Crank** An arm or handle connected to a shaft (or axle) at right angles enabling the shaft to be easily turned.
- D**
- Drive gear** The part of a machine, usually a gear, pulley, lever, crank or axle, where the force first comes into the machine.
- Driven gear** Usually a gear, pulley or lever driven by another one.  
It can also be a lever driven by a cam.

<b>E</b>	<b>Efficiency</b>	A measure of how much of the force that goes into a machine comes out as useful work. Friction often wastes a lot of energy, reducing the efficiency of a machine.
	<b>Effort</b>	The force or amount of force that you or something else puts into a machine.
	<b>Engineering design</b>	A systematic and creative design process integrating the principles of science, technology and mathematics.
	<b>Equilibrium</b>	A stable situation in which all acting forces cancel one another and thus are in balance.
<b>F</b>	<b>Fair testing</b>	Measuring the performance of a machine by comparing its performance under different conditions.
	<b>Fall</b>	Any weight line e.g. cable or rope which is attached to the load or pulley system.
	<b>Follower</b>	Usually a gear, pulley or lever driven by another one. It can also be a lever driven by a cam.
	<b>Force</b>	A push or a pull.
	<b>Friction</b>	The resistance met when one surface is sliding over another, e.g. when an axle is turning in a hole or when you rub your hands together.
	<b>Fulcrum</b>	The point around which something turns or rotates, such as the fulcrum of a lever.
<b>G</b>	<b>Gear</b>	A toothed wheel or cog. The teeth of gears mesh together to transmit movement. Often called a spur gear.
	<b>Gear, bevel</b>	Has teeth that are cut at a 45° angle. When two bevel gears mesh, they change the angle of their axles and movement through 90°.
	<b>Gearing, compound</b>	A combination of gears and axles where at least one axle has two gears of different sizes. Compound gearing results in very big changes to the speed or force of the output compared to the input.
	<b>Gear, crown</b>	Has teeth that stick out on one side looking like a crown. Mesh it with a regular spur gear to turn the angle of motion through 90°.
	<b>Gear, rack</b>	A flat gear with the teeth equally spaced on a straight line that converts rotational motion into linear motion when a spur gear is meshed against it.
	<b>Gear, worm</b>	A gear with one spiral tooth resembling a screw. Mesh it with a pinion to deliver large forces very slowly.
	<b>Gear ratio</b>	A number that indicates how many revolutions a driven gear makes with one complete turn of the drive gear. The gear ratio is determined by dividing the number of teeth on the driven gear by the number of teeth on the drive gear. A ratio of 1:4 means the driven gear turns four times for every one turn of the drive gear.

<b>Gearing down</b>	A small drive gear turns a larger driven gear and amplifies the force from the effort. But the driven gear turns more slowly.
<b>Gearing up</b>	A large drive gear turns a smaller driven gear and reduces the force from the effort. But the driven gear turns more quickly.
<b>I</b>	
<b>Idler</b>	A gear or pulley that is turned by a driver and then just turns another follower. It does not transform the forces in the machine.
<b>Inclined plane</b>	A slanted surface or ramp generally used to raise an object with less effort than is needed to lift it directly. A cam is a special sort of continuous inclined plane.
<b>J</b>	
<b>Jib</b>	The lifting arm of a crane from which the weight line is suspended.
<b>K</b>	
<b>Kinetic energy</b>	The energy of an object that is related to its speed. The faster it travels, the more kinetic energy it has. See also potential energy.
<b>L</b>	
<b>Lever</b>	A bar that turn about a fixed point (fulcrum) when an effort is applied to it.
<b>Lever, first class</b>	The fulcrum is between the effort and the load. A long effort arm and short load arm amplifies the force at the load arm.
<b>Lever, second class</b>	The load is between the effort and the fulcrum. This lever amplifies the force from the effort to make lifting the load easier.
<b>Lever, third class</b>	The effort is between the load and the fulcrum. This lever amplifies the speed and distance the load moves compared to the effort.
<b>Linkages</b>	A mechanical linkage carries movement and forces through a series of rods or beams connected by moving pivot points. Locking pliers, a scissors lift, a sewing machine and a garage door lock all contain linkages.
<b>Load</b>	Any force a structure is calculated to oppose, such as a weight or mass. It can also refer to the amount of resistance placed on a machine.
<b>M</b>	
<b>Machine</b>	A device that makes work either easier or faster to do. It usually contains mechanisms.
<b>Mass</b>	Mass is the quantity of matter in an object. On Earth, gravitational force pulling your matter makes you weigh, for example 70 kg. In orbit, you feel weightless – but you still have a mass of 70 kg. Often confused with weight.
<b>Mechanical advantage</b>	The ratio by which an effort is multiplied, resulting in an advantage in force, speed or distance.
<b>Mechanical advantage, ideal</b>	The measure of performance of an ideal machine under ideal circumstances. Variables like friction are not taken into account when calculating Ideal Mechanical Advantage.

<b>Mechanical advantage, actual</b>	The measure of performance of a real machine. All variables like friction are taken into account when calculating actual Mechanical Advantage.
<b>Member</b>	The name given to individual parts of a structure, e.g. a door frame is made from two upright members and one cross member.
<b>Momentum</b>	The product of the velocity and mass of an object: velocity, not speed, because direction is important; mass, not weight, because it isn't dependant on gravity.
<b>P</b>	
<b>Pawl and Ratchet</b>	An arrangement of a lever or wedge (pawl) and a gear wheel (ratchet) that lets the gear turn in one direction only.
<b>Pinion</b>	Another name for a gear that meshes with a gear rack or worm gear.
<b>Pitch</b>	The distance moved by a screw when the screw is turned through one complete turn (360°).
<b>Potential energy</b>	The energy of an object that is related to its position. The higher up it is, the more potential energy it has. See also kinetic energy.
<b>Power</b>	The rate at which a machine does work (work divided by time). See also work.
<b>Pulley</b>	A wheel with a grooved rim used with a belt, chain or rope.
<b>Pulley, block and tackle</b>	One or more pulleys in a movable frame with ropes or (block and tackle) chains running around them to one or more fixed pulleys. The pulley block moves with the load and reduces the effort needed to lift the load.
<b>Pulley, fixed</b>	Changes the direction of the effort. A fixed pulley does not move with the load.
<b>Pulley, movable</b>	Changes the amount of effort needed to lift the load. A movable pulley moves with the load.
<b>R</b>	
<b>Rack (gear rack)</b>	A specialized gear in the shape of a flat bar with teeth.
<b>Rigid</b>	A rigid material does not easily stretch or bend and does not deform under load.
<b>RPM</b>	Revolutions or turns per minute. This is usually the measure of speed of a motor. The LEGO® motor turns at about 400 rpm unloaded (when it is not driving a machine).
<b>S</b>	
<b>Sheave</b>	A pulley wheel with a grooved rim. The groove is used to hold a rope, belt or cable so that it does not slip off the wheel.
<b>Slip</b>	A belt or rope slipping, usually on a pulley wheel as a safety feature.
<b>Speed</b>	See velocity.
<b>Simple machine</b>	The six basic mechanical devices that form the basis for practically all machines.
<b>Strut</b>	A member of a structure that is in compression. Struts prevent parts of structures from moving towards each other.

<b>T</b>	<b>Tensile forces</b>	Forces in a structure that pull in opposite directions trying to stretch the structure.
	<b>Tie</b>	A member of a structure that is in tension. Ties prevent parts of structures from moving apart, i.e. they 'tie' them together.
	<b>Transmission</b>	A system of gears or pulleys with an input and one or more outputs. A gearbox contains a transmission, and so does a clock.
<b>U</b>	<b>Unbalanced force</b>	A force that is not opposed by an equal and opposite force. An object feeling an unbalanced force must begin to move in some way.
<b>V</b>	<b>Velocity</b>	The speed in a particular direction. To calculate the speed of a vehicle, we divide the distance travelled by the time taken.
	<b>Variable, controlled</b>	A variable that serves as a standard in an experiment.
	<b>Variable, dependent</b>	A variable that is observed and measured in response to the independent variable. The dependent variable will change as a result of changes in the independent variable.
	<b>Variable, independent</b>	A variable which can be manipulated and changed on purpose in an experiment to affect or cause fluctuation in the value of the dependent variable.
<b>W</b>	<b>Work</b>	We calculate the work done by multiplying the force needed to move an object by the distance it is moved (force x distance). See also power.



## LEGO® Element Survey



8x  
Plate, 1x2, blue  
302323

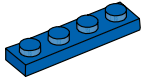

4x  
Plate, 1x4, blue  
371023

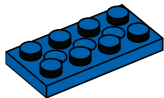

6x  
Plate with holes, 2x4, blue  
370923

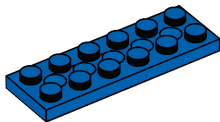

8x  
Plate with holes, 2x6, blue  
4114027

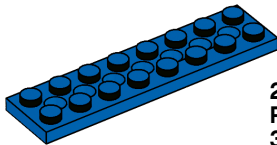

2x  
Plate with holes, 2x8, blue  
373823



4x  
Studded beam, 1x2, blue  
370023

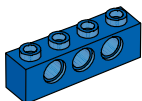

4x  
Studded beam, 1x4, blue  
370123

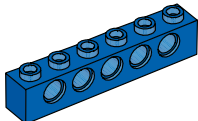

4x  
Studded beam, 1x6, blue  
389423

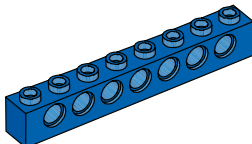

4x  
Studded beam, 1x8, blue  
370223



10x  
Connector peg with friction,  
3-module, blue  
4514553

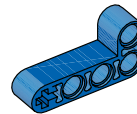

8x  
Angular beam, 4x2-module, blue  
4168114

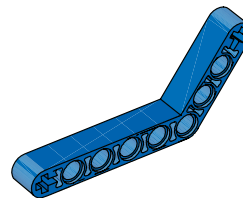

4x  
Angular beam, 4x6-module, blue  
4182884

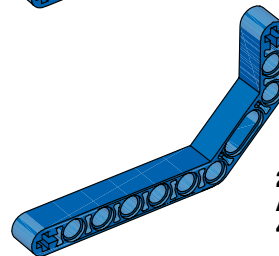



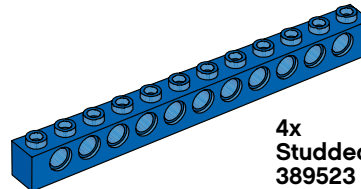



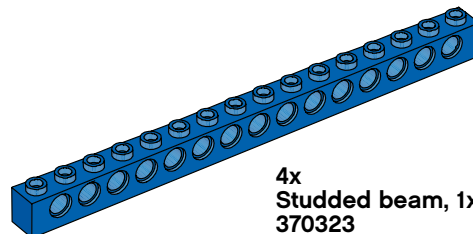



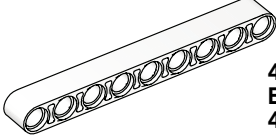

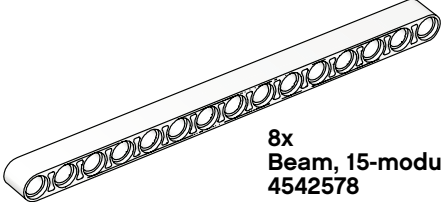
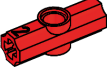
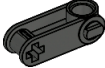





2x  
Angular beam, 3x7-module, blue  
4112000

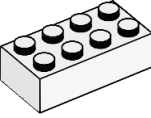





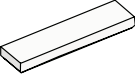

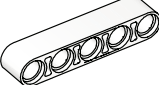
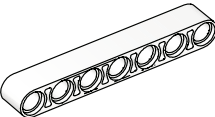



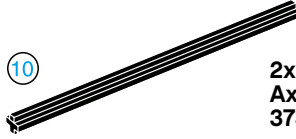

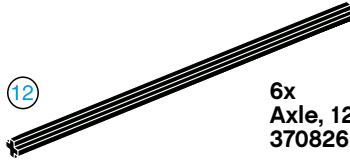





4x  
Studded beam, 1x12, blue  
389523





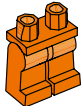
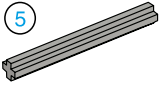
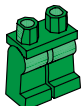





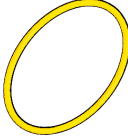

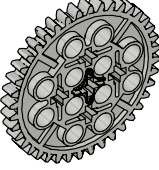
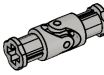



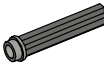
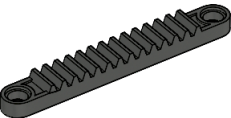

4x  
Studded beam, 1x16, blue  
370323

	<b>14x</b> Axle, 2-module, red 4142865		<b>4x</b> Beam, 9-module, white 4156341
	<b>14x</b> Connector peg with bushing, red 4140806		<b>8x</b> Beam, 15-module, white 4542578
	<b>4x</b> Angular block, 2 (180°), red 4234429		<b>2x</b> Steering arm, black 4114670
	<b>10x</b> Angular block with crosshole, red 4118897		<b>2x</b> Bearing for steering arm, black 4114671
	<b>4x</b> Cross block, 3-module, red 4175442		<b>4x</b> Angular block, 1 (0°), dark grey 4210658
	<b>2x</b> Tube, 2-module, red 4526984		<b>4x</b> Angular block, 3 (157,5°), black 4107082
	<b>4x</b> Studded beam, 1x2 with crosshole, white 4233486		<b>28x</b> Connector peg with friction, black 4121715
	<b>2x</b> Brick, 2x4, white 300101		<b>4x</b> Tyre, 30,4x4, black 281526
	<b>2x</b> Brick, 2x2 round, white 614301		<b>4x</b> Tyre, 30,4x14, black 4140670
	<b>4x</b> Roof brick, 1x2/45°, white 4121932		<b>4x</b> Tyre, 43,2x22, black 4184286
	<b>2x</b> Tile, 1x4, white 243101		
	<b>2x</b> Beam, 3-module, white 4208160		
	<b>2x</b> Beam, 5-module, white 4249021		
	<b>2x</b> Beam, 7-module, white 4495927		

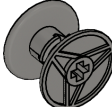

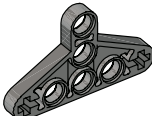
	12x Connector peg with axle, beige 4186017		2x Axle, 10-module, black 373726
	4x Connector peg, 3-module, beige 4514554		6x Axle, 12-module, black 370826
	16x Bushing, 1/2-module, yellow 4239601		1x Minifigure, ponytail wig, black 609326
	4x Connector peg, handle, grey 4211688		1x Minifigure, cap, red 448521
	8x Connector peg, grey 4211807		2x Minifigure, head, yellow 9336
	16x Bushing, grey 4211622		1x Minifigure, body, white with surfer 4275606
	8x Axle extender, 2-module, grey 4512360		1x Minifigure, body, white with flowers 4275536
	8x Axle, 3-module, grey 4211815		1x Minifigure, legs, orange 4120158
	4x Axle, 5-module, grey 4211639		1x Minifigure, legs, green 74040
	8x Axle, 4-module, black 370526		
	2x Axle, 6-module, black 370626		
	2x Axle, 8-module, black 370726		

	2x Gear, 16-tooth, grey 4211563		2x Belt, 33 mm, yellow 4544151
	4x Gear, 24-tooth crown, grey 4211434		2x Belt, 24 mm, red 4544143
	2x Gear, 40-tooth, grey 4285634		2x Belt, 15 mm, white 4544140
	2x Gear, 10-tooth rack, grey 4211450		1x Universal joint, 3-module, grey 4525904
	2x Worm gear, grey 4211510		4x Hub, 18x14, grey 4490127
	1x Differential, 28-tooth, dark grey 4525184		4x Hub, 24x4, grey 4494222
	4x Gear, 24-tooth, dark grey 4514558		4x Hub, 30x20, grey 4297210
	6x Gear, 8-tooth, dark grey 4514559		6x Connector peg, 1½-module, dark grey 4211050
	2x Gear, 12-tooth double bevel, black 4177431		4x Axle with knob, 3-module, dark grey 4211086
	1x Gear, 14-tooth rack, black 4275503		4x Cam wheel, dark grey 4210759
	6x Gear, 12-tooth bevel, beige 4514556		1x Bobbin, dark grey 4239891
	2x Gear, 20-tooth bevel, beige 4514557		2x ½ beam, triangle, dark grey 4210689
	2x Gear, 20-tooth double bevel, beige 4514555		

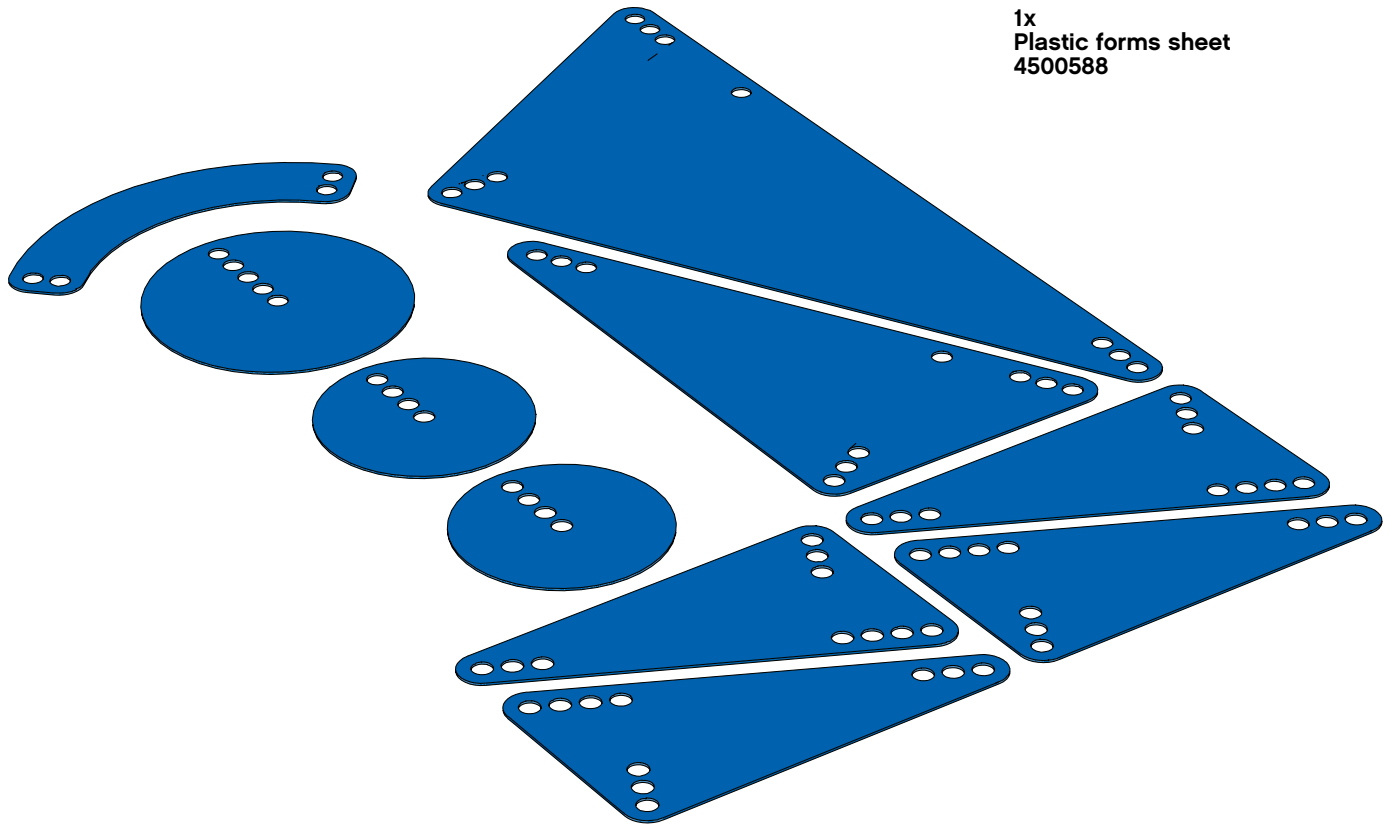

1x  
Plastic forms sheet  
4500588

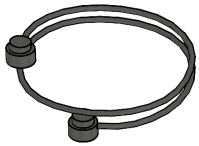

2x  
String, 40-module with knobs,  
black  
4528334

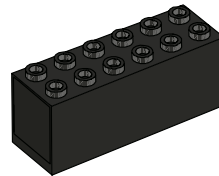

1x  
Weight element, black  
73843

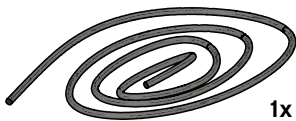

1x  
String, 2 m, black  
4276325

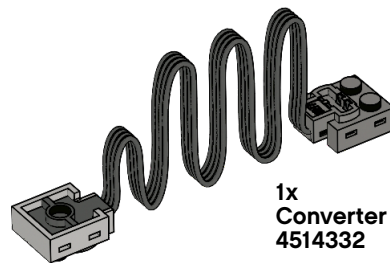

1x  
Converter cable, black  
4514332

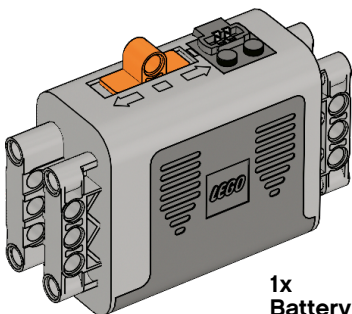

1x  
Battery box, 9V, grey  
4506078

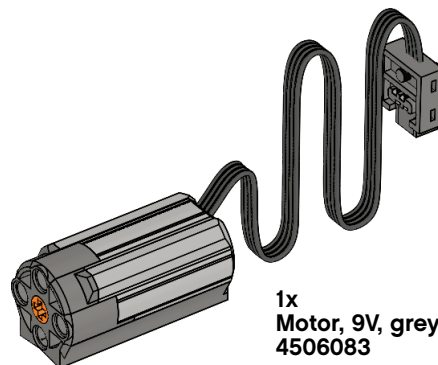

1x  
Motor, 9V, grey  
4506083

The machines shown in the video sequences are kindly provided by:  
Beam Balance: Kig-Ind Antik  
Tower Crane: Jorton A/S  
Ramp: Totempo. Ford Motor Company A/S  
Gear Racer: Ferrari. Silkeborg Technical School

LEGO and the LEGO logo are trademarks of the/son des marques  
de commerce du/son marcas registradas de LEGO Group.  
©2016 The LEGO Group.

[LEGOeducation.com](http://LEGOeducation.com)



education